

RetroAntenna®

PA01 / PA03 / PA03B
Power Antenna

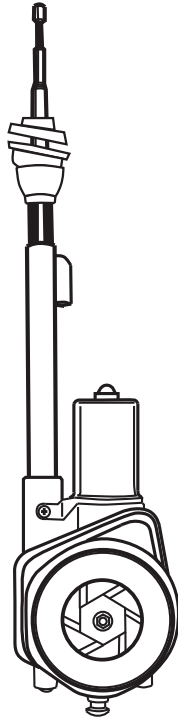

PA01

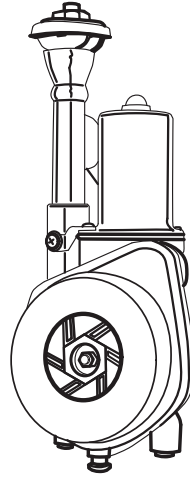

PA03/PA03B

Installation Guide

The information enclosed in this installation guide is intended to provide a general outline to assist you during the process of installation. This guide does not cover every installation possibility, vehicle, or aspect of the installation process.

Retro Manufacturing, LLC, or its subsidiaries assume no responsibility for proper or improper installation. Every attempt has been made to make this installation guide as informative as possible. This guide may be updated from time to time, and specifications are subject to change without notice. Please check our website (help.retromanufacturing.com) for the latest updates.

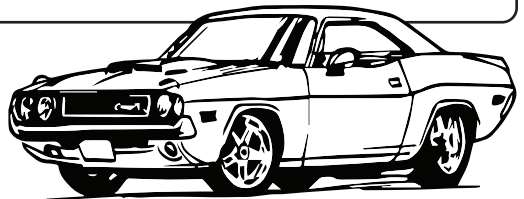

Retro
MANUFACTURING®

INSTALLATION

Welcome

Thank you for purchasing a RetroAntenna® Power Antenna. This antenna features fully automatic operation. Please note that this antenna does not work with antenna systems requiring a switch. Our antenna uses a standard end that is designed to fit most applications. However, some factory radios made after 1988 use a unique connector and may need an adapter. Contact a local car audio shop for the correct adapter for your application if one is required.

Installing the Antenna

1. Disconnect the battery before you begin the installation. Make sure the area for the antenna has enough clearance to house the antenna. The PA01 antenna requires 11 1/2 inches or 29cm of clearance. The PA03 requires 8 1/2 inches or 22cm of clearance.

Note: Six mounting bases are provided with the antenna: five of varying angles and one 0 degree base preinstalled on the antenna (**see Figure 1**).

2. If necessary remove the preinstalled 0 degree base and choose from the other five to suit your needs. Select the proper base with the correct angle for your fender (**see Figure 1**). The five fixed angle bases require a 7/8 inch or 22mm hole. The 0 degree base requires a 1 inch or 25mm hole.

Note: If no adequate hole exists, a 1/8 inch or 3mm pilot hole must be drilled then enlarged with a hole saw or drill bit to one of the sizes listed above depending on the base you will use.

3. Remove all burrs, paint or dirt from the underside of the hole.

4. Install the new antenna from the underside of the fender and assemble the base above the fender (**see Figure 2**). Be sure the metal retainer cup is in place and the adjustable mounting base rests evenly on the underside of the fender to alleviate any possible damage to the vehicle or antenna. Align the mast vertically by slightly tightening the antenna mounting nut while adjusting the mast to be vertical.

5. Secure the bottom of the motor assembly with the supplied metal strap. There are holes in the strap designed to accommodate various mounting positions. It may be necessary to bend the strap to mount the motor assembly.

6. Attach the black ground wire to the chassis. Be sure the ground wire is attached to a clean mounting point for proper operation. If the ground wire is not grounded correctly, the antenna will not function.

7. With the bottom of the antenna motor assembly secured, the mast at the desired angle, and the adjustable mounting base resting evenly on the underside of the fender, tighten the mounting nut firmly to secure the antenna assembly. Do not overtighten the nut. Overtightening the nut may strip or break the mounting threads or damage the contact spring causing improper antenna operation.

8. Attach the drain tube to the bottom of the motor assembly and route it to the outside of the car. Avoid kinking or bending the drain tube (**see Figure 2**).

9. Route the electrical wiring and coaxial cable into the dash area inside the vehicle interior to plug it into your radio (**see Figure 3**). A 5/8 inch or 16mm hole will be required to route the wire through the inner fender. Avoid routing cables through the engine compartment, and near hot or high current parts. Antenna cables may pick up interference from high current parts and wiring.

10. **Electrical Wiring:** For radios with a power antenna wire, connect the blue wire from the antenna to the power antenna wire from the radio (usually blue), then connect the coaxial cable from the antenna to the radio (**see Figure 3**). The red power wire from the antenna can be connected at the fuse block, battery or any other constant +12 volt location. If your radio does not have a power antenna wire you may need to connect the blue wire to a switched 12-volt ignition source.

IMPORTANT NOTES

- For optimum operation and reception, you must periodically clean the mast with a damp cloth. Always clean the mast while it is fully extended. Do not oil or grease the antenna or motor assembly. Doing so will damage the motor.
- This power antenna is designed to withstand extremely cold temperatures, but under severe icing conditions the antenna could fail to extend or retract. If this happens, turn the radio on and off three or four times to help free the antenna mast. The antenna motor will not be damaged if the mast does not extend. A special clutch protects the motor from any possible damage from a frozen mast.
- Always remember to retract the antenna when entering a car wash or low clearance areas.
- There are no user serviceable parts in the motor assembly, and it should never be taken apart.

- Periodically inspect the drain tube for blockage or kinks.
- Damage caused by disassembly, unauthorized accessories or incorrect wiring will void your warranty.

Figure 1

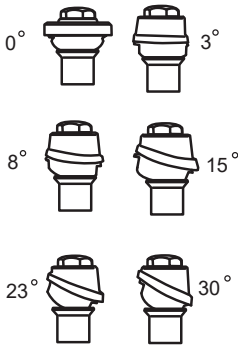

Included mounting bases

Figure 2

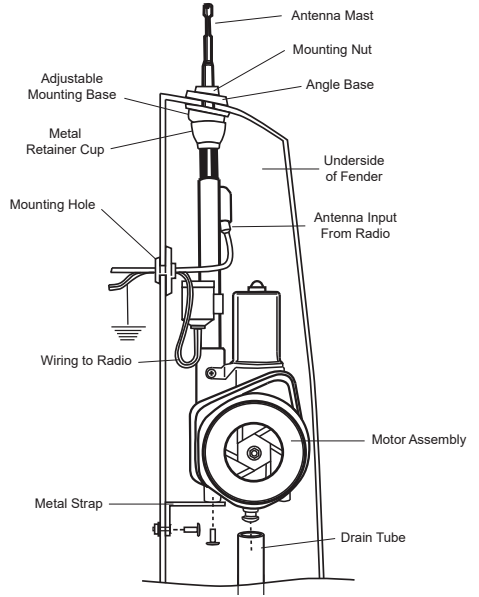

Weather Resistant Rubber Boot

For wet climates we now offer a weather resistant rubber boot to protect the Power Antenna from excessive moisture.



Replacement Parts

Replacement antenna masts and adapters are available on our website.

www.RetroManufacturing.com

Figure 3

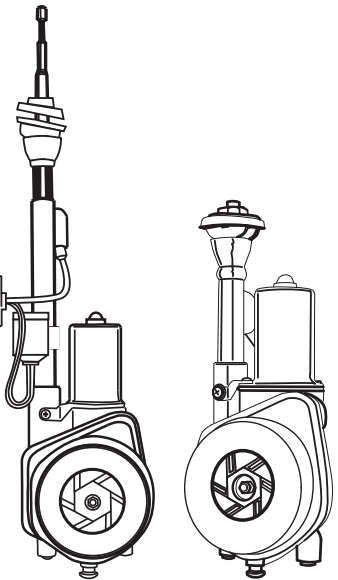
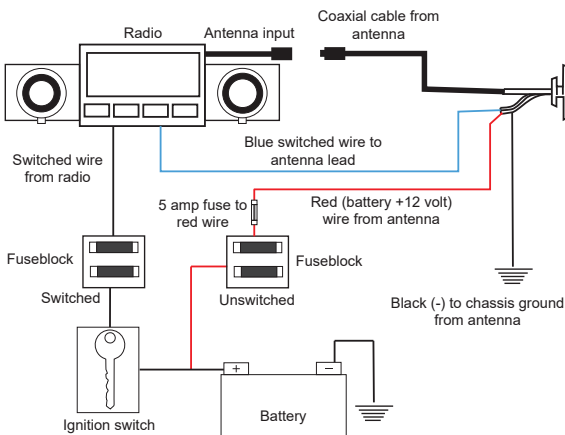

PA01

PA03/PA03B

Warranty

Your Power Antenna comes with a manufacturer's warranty covering any defects in materials and workmanship. Retro Manufacturing, LLC (collectively referred to as "the warranter"), at its option, will either (a) repair your unit with new or refurbished parts or (b) replace it with a new or refurbished unit. The warranty period starts from the original purchase date and is valid for the length of time indicated in the chart below. The decision to repair or replace will be made by the warranter.

ITEM	WARRANTY
Antennas	One (1) Year

During the "Parts" warranty period, there will be no charge for parts. You must mail in your unit during the warranty period at your expense. This warranty only applies to products purchased directly from Retro Manufacturing or an authorized dealer. This warranty is extended only to the original purchaser of a new product that was not sold "as is." A purchase receipt or other proof of the original purchase date is required for warranty service.

To handle a warranty issue go to www.retromanufacturing.com/returns-center and fill out the Returns Form for a Return Authorization (RA) number. A RA number must accompany all returns and warranty issues. Any product received without a RA number will be refused.

LIMITED WARRANTY-LIMITS AND EXCLUSIONS

This warranty ONLY COVERS failures due to defects in materials and workmanship and DOES NOT COVER normal wear and tear or cosmetic damage. The warranty ALSO DOES NOT COVER damages that occurred during shipment, failures which are caused by products not supplied by the warranter, failures that result from accident, misuse, abuse, neglect, bug infestation, mishandling, misapplication, alteration, faulty installation, set-up adjustment, maladjustment of consumer control, improper maintenance, improper antenna, inadequate signal reception or pickup, power line surge, improper voltage supply, lightning, modification, commercial use (such as use in hotels, offices, restaurants, or other business uses) or rental use of the product, or service by anyone other than Retro Manufacturing, LLC, or damage that is attributable to acts of God.

THERE ARE NO EXPRESS WARRANTIES EXCEPT AS LISTED UNDER LIMITED WARRANTY. THE WARRANTER IS NOT LIABLE FOR INCIDENTAL OR CONSEQUENTIAL DAMAGES RESULTING FROM THE USE OF THIS UNIT OR ARISING OUT OF ANY BREACH OF THIS WARRANTY. (As examples, this excludes damages for lost time, the cost of having someone remove or re-install an installed unit if applicable, travel to and from the servicer, and loss of media, data, or other memory contents. The items listed are not exclusive but are for illustration only.) ALL EXPRESS AND IMPLIED WARRANTIES, INCLUDING THE WARRANTY OF MERCHANTABILITY, ARE LIMITED TO THE PERIOD OF THE LIMITED WARRANTY.

Some states do not allow the exclusion or limitation of incidental or consequential damages or limitations on how long an implied warranty lasts, so the exclusions may not apply to you. This warranty gives you specific legal rights, and you may also have other rights which vary from state to state. If a problem with this unit develops during or after the warranty period, you may contact your dealer or Retro Manufacturing, LLC.



7470 Commercial Way, Henderson, NV 89011
Phone: 888.325.1555 • Fax: 702.483.2229

©2022 Retro Manufacturing, LLC | Published: 02/20/24