



**Installation
& Assembly
Manual**



MODERN SOUND FOR YOUR CLASSIC

TABLE OF CONTENTS

What's in the Box	3
Precautions	5
Attaching the Radio Face	7
Attaching the InfiniMount Brackets	9
Installing the Control Shafts	10
Adjusting Control Shaft Depth	11
Wiring the Radio	12
Using a Bezel	13
Using a Faceplate	14
Attaching the Backstrap	15
Completing the Installation	16
Troubleshooting	17
Purchase Notes	18

What's in the box

Thank you for purchasing a RetroSound® radio. RetroSound® radios combine classic styling with the advanced features you expect from a modern car stereo. Your RetroSound® radio consists of two main parts: the **Radio Face** and the **Radio Motor**.

NOTE: All hardware will not be required for every installation. Extra items are included to help you get the right fit for your vehicle.

Radio Face Box

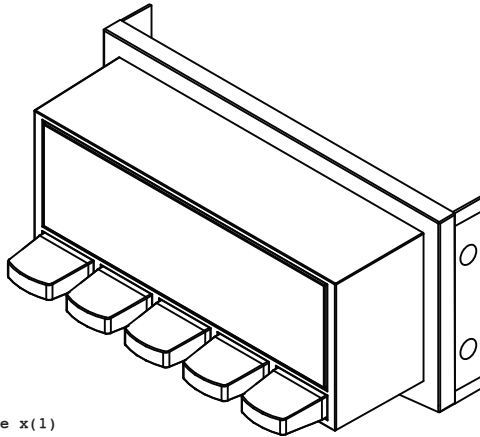

A Radio Face x(1)

Radio Face will vary depending on product purchased.

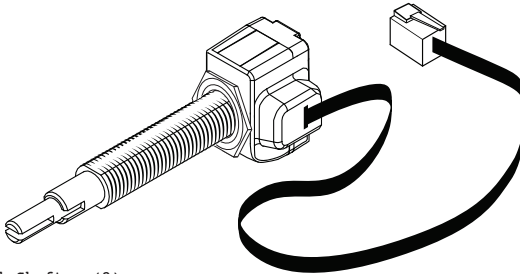

B Control Shafts x(2)



C Shaft Nuts x(6)



D Shaft Washers x(8)



E Small Screws x(4)

What's in the box

Radio Motor Box

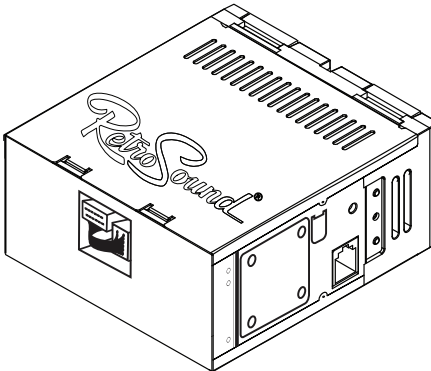

F Radio Motor x(1)



G Main Wiring Harness x(1)

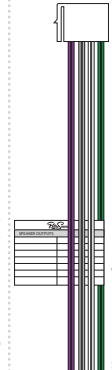

H Speaker Harness x(1)

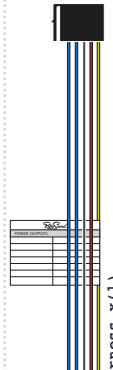

L Power Harness x(1)

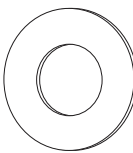

J Large Washer x(8)



K InfiniMount Screws x(10)



L 6mm Nut x(4)



O Dual Thread Bolt x(1)

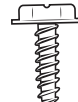

P 10 mm Self Tapping Screw x(1)

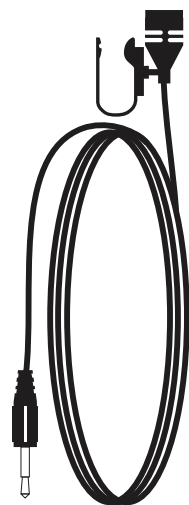

V Bluetooth Mic x(1)
**Not available in all models*

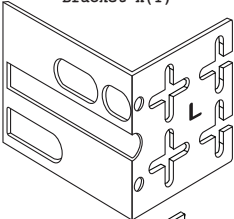

M Left InfiniMount Bracket x(1)



Q Lock Washer x(3)



R Self Tapping Screw x(1)



S 7 mm Nut x(1)



T Rubber Stopper x(1)



E Backstrap x(1)

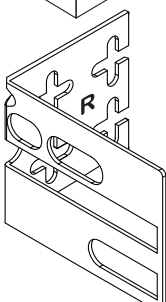

N Right InfiniMount Bracket x(1)



W Large Plastic Spacer x(2)



X Cupped Plastic Spacer x(2)

4

tech@retromanufacturing.com

PRECAUTIONS

PLEASE OBSERVE THESE PRECAUTIONS WHEN INSTALLING AND USING THIS UNIT:

This user's manual does not cover all possible installation scenarios. Please be sure to follow the instructions carefully while attempting installation. If you feel you cannot install this unit yourself, consult with a local car audio professional.

Retro Manufacturing, LLC is not liable for any problems resulting from improper installation of the unit.

If you have questions about installing your radio, contact us at **tech@retromanufacturing.com** or by calling **888.325.1555**.

- If the unit does not turn on, check all wiring first. Then check the fuse in your vehicle's fuse panel and the fuse at the unit's wiring harness. If either fuse has failed, eliminate the cause of the failure, and replace the fuse with one prescribed for this unit.
- Do not disassemble or modify the unit or attempt to repair it yourself. If the unit needs to be repaired, consult your dealer or Retro Manufacturing, LLC.
- This unit is not designed for a marine environment. Please do not use the unit where it will be exposed to moisture or excessive dust. Exposure to moisture will damage the unit and void your warranty.
- Use caution when routing wiring and cables to prevent them from being caught in the vehicle chassis, or damaged by screws or moving parts, such as seat rails.
- Cutting the main wiring harness, antenna lead, USB or auxiliary cables **will void the warranty** of your radio.
- If mounting the Radio Face or Radio Motor remotely, use extreme caution not to damage these units' internal parts when choosing brackets and screws.
- Never install the unit in a location where it interferes with your field of vision.
- Use the supplied metal backstrap to secure the rear of the unit. Failure to secure the back of the unit will damage the shafts and **will void the warranty**.

PRECAUTIONS

- Never splice into the power lead to supply other equipment with power.
- After installation and wiring, always check the normal operation of other electrical equipment.
- Make sure that no wires interfere with driving or getting in and out of the vehicle. Insulate all exposed wires to prevent short-circuiting or electric shock.
- Keep the volume of your radio at a level that allows you to hear outside noises, such as emergency sirens and train crossing warnings. Prolonged exposure to high volume levels may also result in hearing loss.
- This unit is designed for operation with a negative ground 12-volt DC battery system. Do not operate this unit with other battery systems, especially an 18-volt or 24-volt DC or a positive ground system. If you have a 6-volt system, you need to either convert to 12-volt DC or purchase a separate inverter that would increase the voltage to 12-volts. NOTE: The inverter needs to be rated at 10 amps or higher for the radio to operate properly.

The information enclosed in this user's manual is to be used as a guide to assist you in the assembly and installation of your radio. This guide does not cover every installation possibility, every vehicle, or every aspect of the installation process.

Retro Manufacturing, LLC or its subsidiaries assume no responsibility for any installation. This manual may be updated from time to time.

Please check our website for the latest updates:

www.retromanufacturing.com

Attaching the Radio Face

Parts Needed

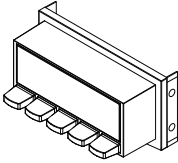

(A) Radio Face x(1)

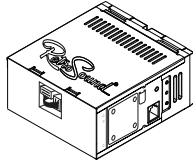

(F) Radio Motor x(1)



(E) Small Screws x(4)

Step #1 Connect ribbon cable to the Radio Face.

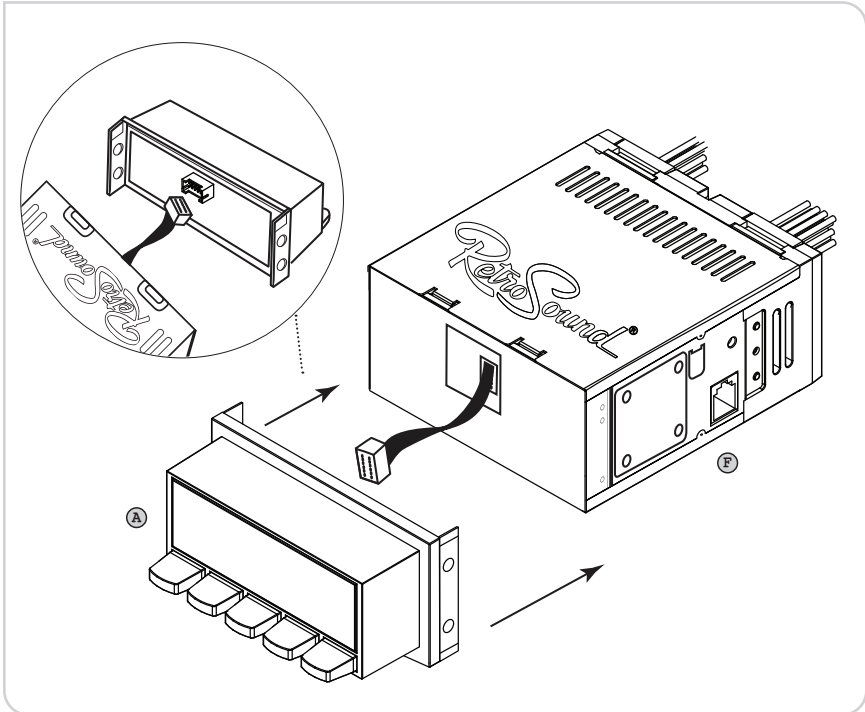

Plug the ribbon cable from the Radio Motor(F) into the Radio Face(A). The ribbon cable is attached to the Radio Motor in the square opening on the front of the Radio Motor. Plug the loose end into the Radio Face making sure the other end is plugged into the Radio Motor securely.

Attaching the Radio Face

Step #2 Attach the Radio Face.

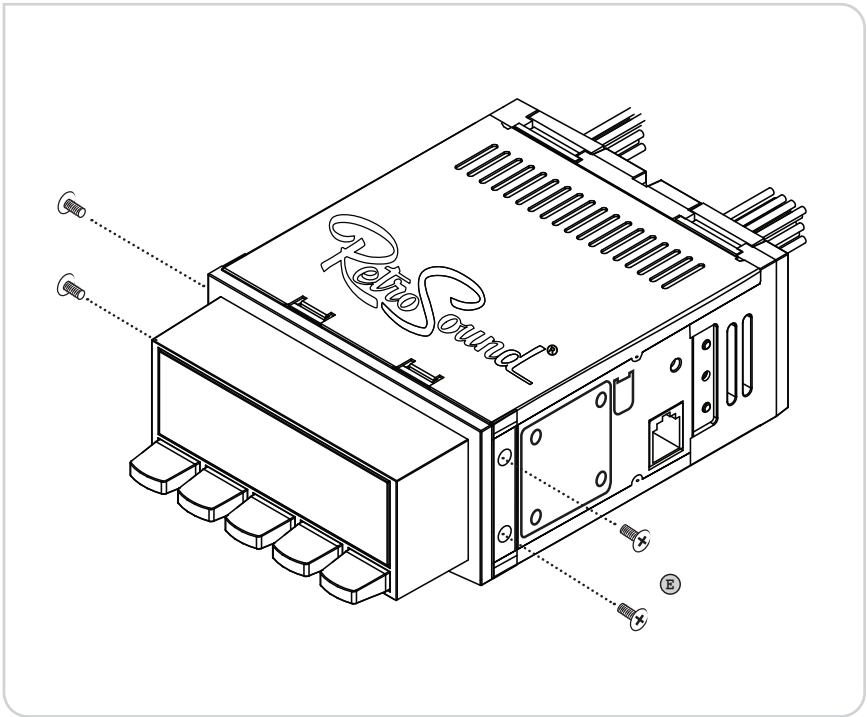

Before attaching the Radio Face ensure the RetroSound® logo on the Radio Motor is facing upwards. Attach the Radio Face to the Radio Motor with the four Small Screws(E).

Special Instructions for **APACHE** Radio Users

Apache Radio Face users will need to take an additional step to set up your radio to work in Apache Mode. Once the radio is fully assembled, installed, and powered on, press and hold the Right-Front knob for three seconds to access the sub-menu system. You will see AUTO SEEK or MANUAL. Release and press the Right-Front knob repeatedly to SEL PANEL, then rotate the Right-Front knob clockwise to show NORMAL or APACHE panel choices. With the APACHE panel selected, press the Right-Front knob to set.

Attaching the InfiniMount Brackets

Parts Needed

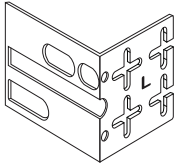

(M) Left InfiniMount Bracket x(1)

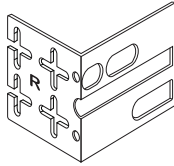

(N) Right InfiniMount Bracket x(1)



(K) InfiniMount Screws x(8)

Step #3 Attach the InfiniMount Brackets.

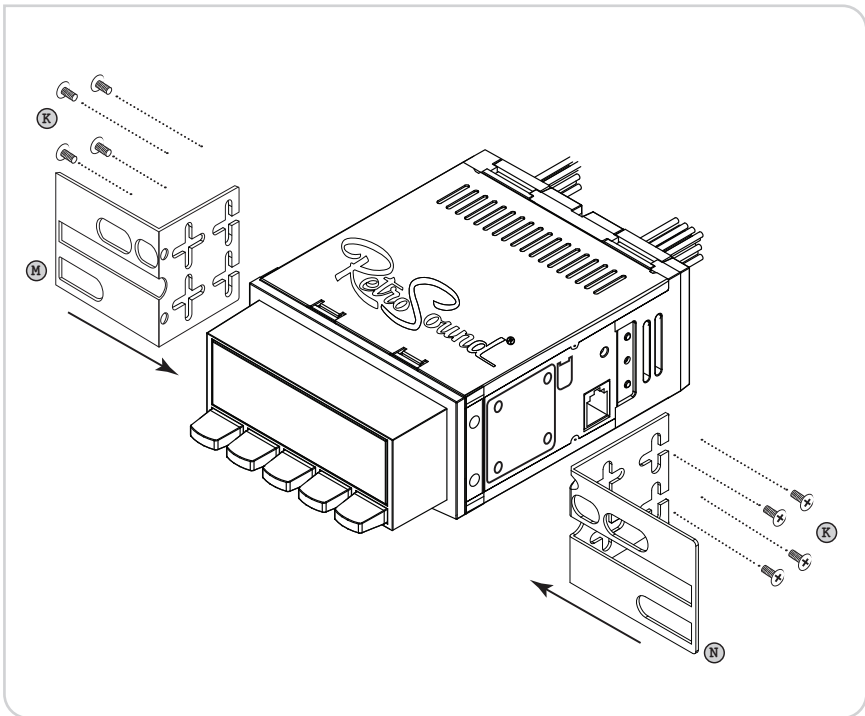

Attach both InfiniMount Brackets(M,N) to Radio Motor using the supplied InfiniMount Screws(K) (the brackets are marked with an “L” for left and an “R” for right). Make sure the RetroSound® logo on the Radio Motor is facing upwards. Before tightening the screws, you may also move the brackets forward, backward, up, or down as needed. The InfiniMount Brackets may be rotated, cut, or bent to achieve the perfect fit. A minimum of two screws must be used on each bracket to secure them correctly.

Installing the Control Shafts

Parts Needed

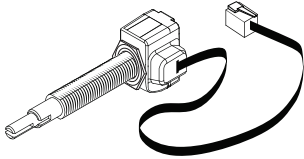

B Control Shafts x(2)



C Shaft Nuts x(4)



D Shaft Washers x(4)

Step #4 Measure & Set Shaft Width

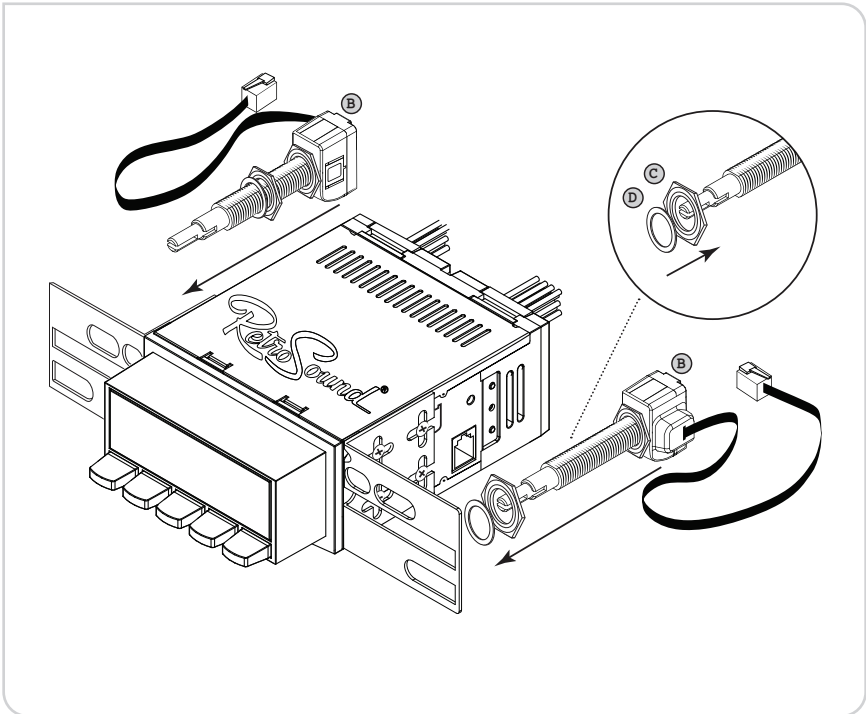

Measure vehicle dash for proper width (shaft hole center to center) and offset of the shafts (some vehicle shaft locations may be offset from the radio display). Match the shaft locations from your dash to the proper InfiniMount Bracket location. Place a Shaft Nut(C) and Shaft Washer(D) on each shaft about halfway down; the Shaft Nuts will be adjusted in the next step to set the proper depth.

Installing the Control Shafts

Step #5 Set Control Shaft Depth

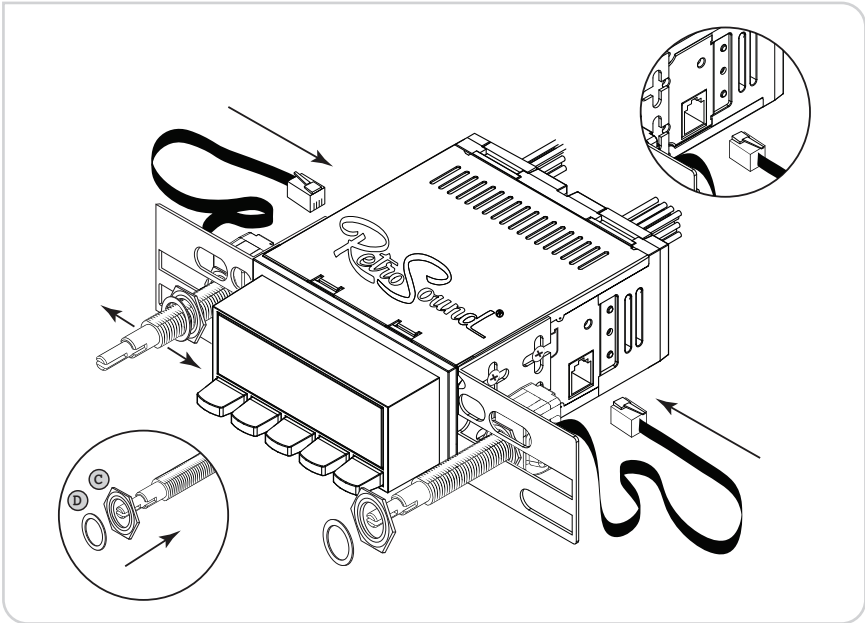

Insert the Control Shafts into InfiMount Brackets, add a Shaft Nut(C), and Shaft Washer(D) to each shaft. To start, bring the shafts forward until the brass portion is about a quarter-inch past the display face. Adjust the depth of the shafts as needed by moving the shaft nuts forward or backward. Once you ensure the shafts are at the proper width and depth, snug down the shaft nuts to finger tight (DO NOT OVERTIGHTEN). With the shafts securely in place, plug the shaft cables into the Radio Motor.

Adjusting Control Shaft Depth

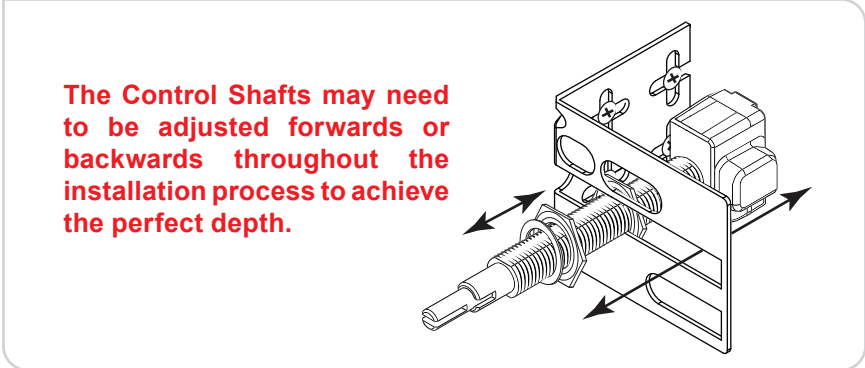

Wiring the Radio

Parts Needed

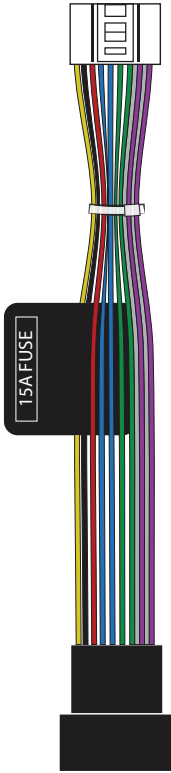

Ⓒ Main Wiring Harness
x(1)

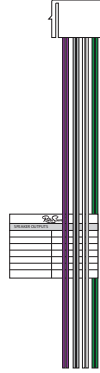

Ⓗ Speaker Harness x(1)



Ⓙ Power Harness x(1)

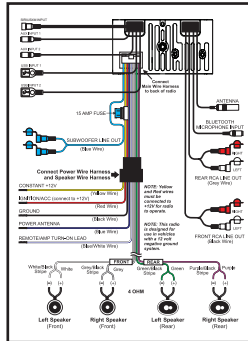

Your connections will vary depending on the unit purchased. Refer to the wiring diagram included in your Radio Motor box for specific connections.

Step #6 Connect the Wiring Harness

Locate the three wiring harnesses: Main Wiring Harness(G), Speaker Harness(H), and Power Harness(I) from your Radio Motor box. Using the Power Harness and Speaker Harness, connect the bare wire ends of your power and speaker wires to the appropriate power and speaker locations in your vehicle (see wiring diagram included in your Radio Motor box). Then connect the Main Wiring Harness to the back of the Radio Motor. Do not connect the Speaker and Power Harnesses to the Main Wiring Harness until Step #7.

If you find this step too difficult, consult with a local audio installation professional, or contact us at tech@retromanufacturing.com for assistance.

Using a Bezel

Optional: Install the Bezel

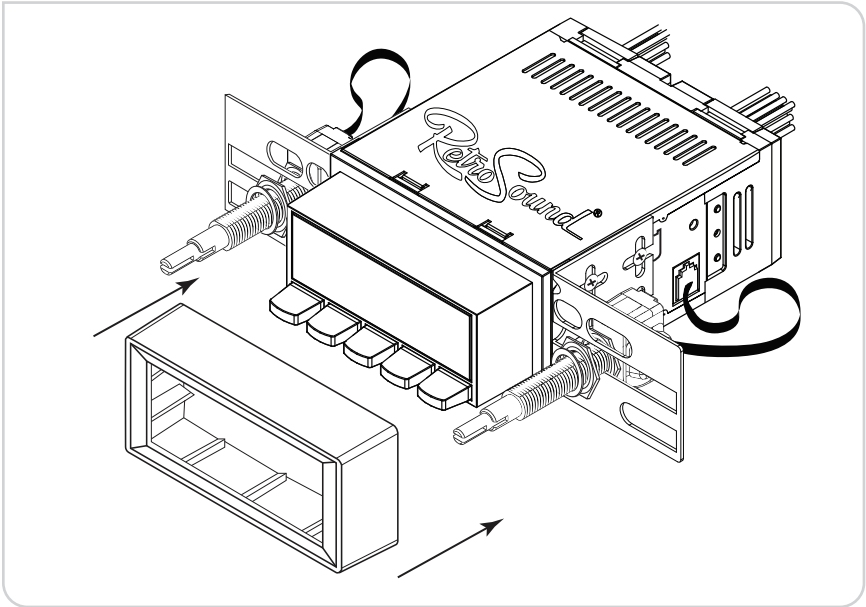

If you are using a Bezel, slide the Bezel over the Radio Face **BEFORE** inserting the assembled radio into the dash. To achieve a proper fit, you may need to use the Cupped Plastic Spacers(X) in front of the dash, before the final nuts and washers are applied. If the fit does not look correct for your particular installation, revisit Step #5 to adjust the shaft depth as necessary.

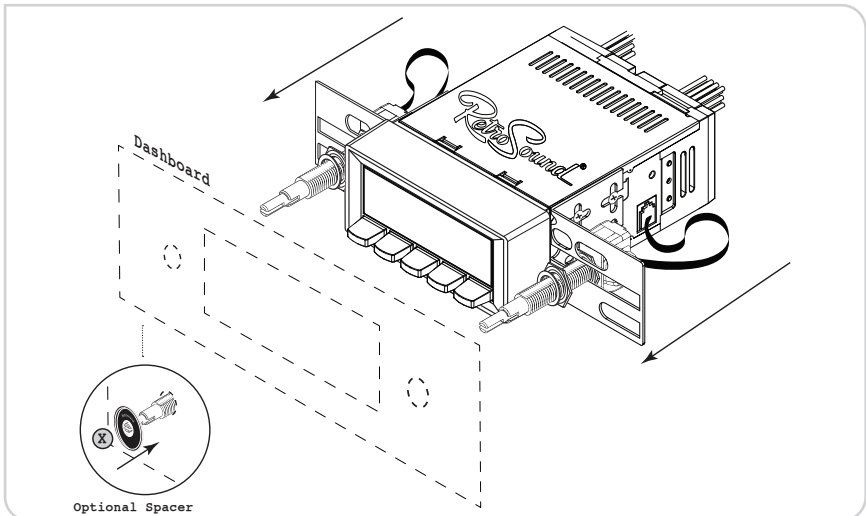

Using a Faceplate

Optional: Install the Faceplate

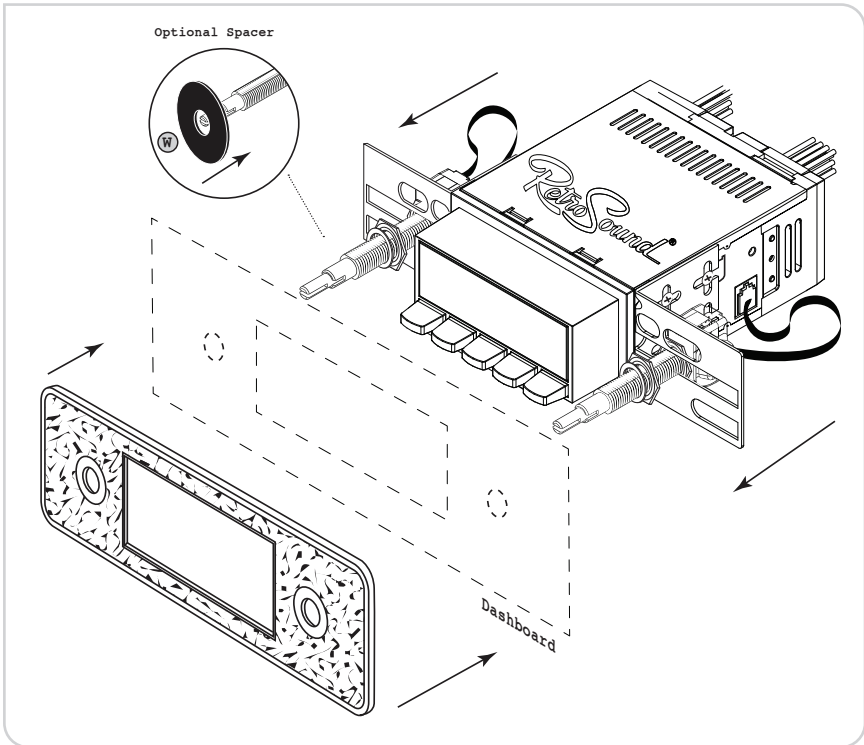

If you are using a Faceplate, slide the radio into the opening from behind the dash **BEFORE** adding the Faceplate. To achieve a proper fit, you may need to use the Large Plastic Spacers(W). If using the spacers, place them on the shafts behind the dash. Align the Faceplate over the shafts from the front of the dash. The Radio Face should align flush with the Faceplate, and the shafts should only protrude about a quarter inch past the Radio Face. If the fit does not look correct for your particular installation, revisit Step #5 to adjust the shaft depth as necessary.

IMPORTANT STEP: Attach the Backstrap!

Before completing the installation with the final nuts and washers, it is **IMPORTANT** that you secure the unit to your vehicle using the supplied Backstrap to support the unit's weight properly. Failure to attach the Backstrap will damage the Control Shafts and void your warranty. (See the instructions on the following page.)

Attaching the Backstrap

Parts Needed

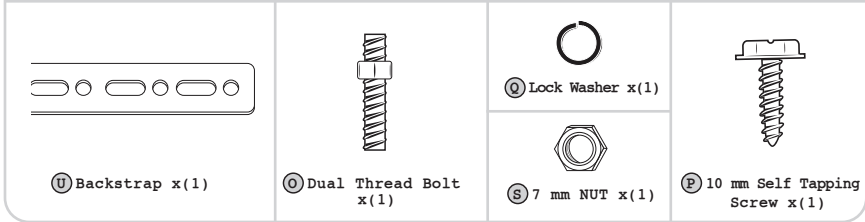

Step #7 Attach the Backstrap

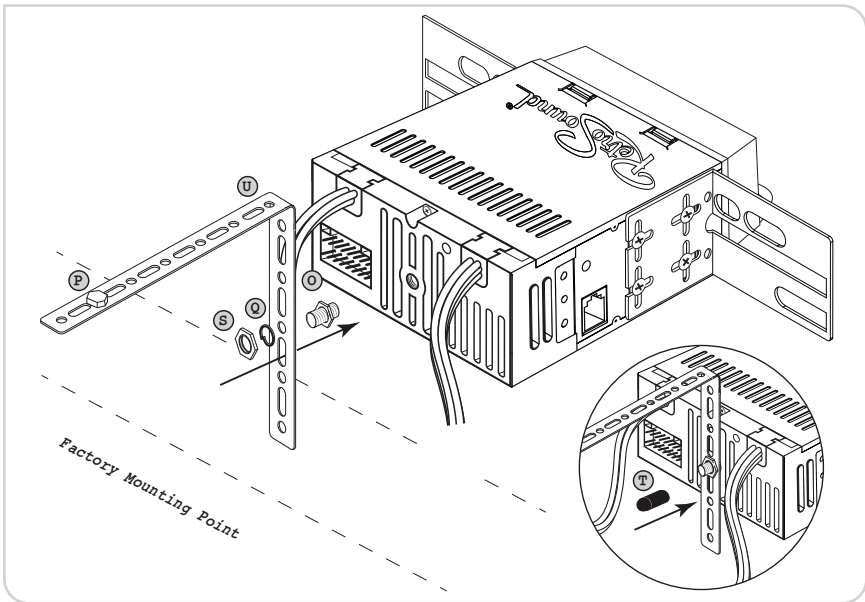

Before attaching the backstrap, connect both the Speaker Harness(H) and Power Harness(I) to the female plug of the Main Wiring Harness(G). If you are using the Bluetooth Mic(V), USB extensions, or any AUX devices, connect them at this time and route the cables to their proper locations. Next, you will need to secure the back of the radio using the supplied Backstrap(U) and mounting hardware. The backstrap mounts to the threads on the back of the Radio Motor using the Dual Thread Bolt(O), Lock Washer(Q), and 7 mm Nut(S) and can be bent or adjusted to align with the mounting point of the original factory radio behind the dash. The Rubber Stopper(T) can be added if needed to cover the Dual Thread Bolt. Secure the other end of the backstrap to the factory mounting point on your vehicle using the 10 mm Self Tapping Screw(P) or the Self Tapping Screw(R).

Completing the Installation

Parts Needed



© Shaft Nuts x(2)



Ⓓ Shaft Washers x(2)

Step #8 Complete the Installation

Bezel: Once the radio is supported from the rear and set into the dash with the Bezel installed, add a final Shaft Washer(D) and Shaft Nut(C) to each Control Shaft.

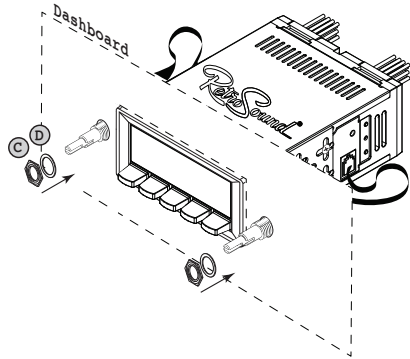

Faceplate: Once the radio is supported from the rear and set into the dash, add your Faceplate and a final Shaft Washer(D) and Shaft Nut(C) to each Control Shaft.

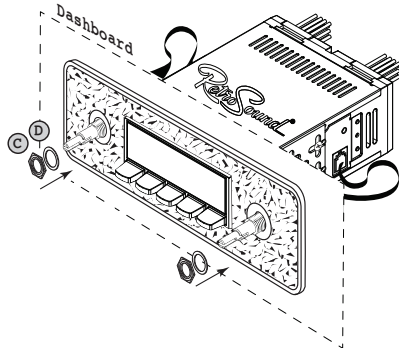

To complete the installation of your radio, add the rear and front knobs to both Control Shafts.

NOTE: All hardware will not be required for every installation. Extra items are included to help you get the right fit for your vehicle.

Troubleshooting

Problem	Possible Cause	Action to Solve Problem
Radio will not turn on (no lights, no sound)	Constant +12V (yellow) wire not connected or incorrect voltage	Check all connections are connected proper voltage with a volt meter. Voltage range: 12-15 volts
	+12V ignition/accessory (red) wire not connected or incorrect voltage	Check +12V accessory (red) wire connection
	Ground (black) wire not connected	Check ground connection
	Fuse on constant +12V (yellow) wire is blown	Replace blown fuse
No sound heard from unit but unit lights up	Volume turned all the way down	Increase radio volume
	Internal amp in protection mode	Check speaker leads for any grounded or shorted wires
	Wrong source mode selected	Make sure the unit is in the desired source mode (RADIO,AUX)
Unit blows fuses	Possible short in wiring or incorrect fuse used	Make sure only fuses with correct 15 amp ratings are used and check all wiring connections for possible short
	Battery hooked up backwards	Make sure battery is properly connected

For replacement parts, visit our website at www.retromanufacturing.com, contact us by calling **888.325.1555** or send an email to tech@retromanufacturing.com. (see “What’s in the Box” on pages 3-4 to confirm the part(s) needed).

Purchase Notes

Record the place and date of purchase for future reference.

Model No. _____

Serial No. _____

Purchase Date _____

Purchased From _____

Keep this information and your sales receipt in a safe place.



7470 Commercial Way, Henderson, NV 89011

Phone: 888.325.1555 • Fax: 702.483.2229

©2020 Retro Manufacturing, LLC | Published: 11/25/20

Retro[®]
MANUFACTURING

7470 Commercial Way | Henderson, NV 89011
Phone: 888.325.1555 • Fax: 702.483.2229

MODERN SOUND FOR YOUR CLASSIC

  **RETROMANUFACTURING**