

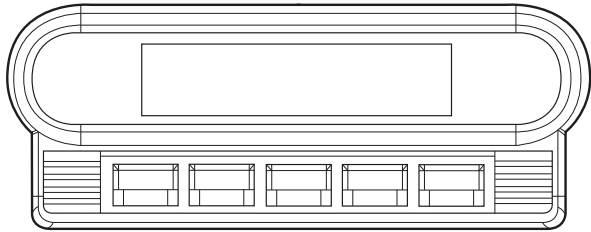

### What's in the Box

#### Radio



#### Shafts & Hardware

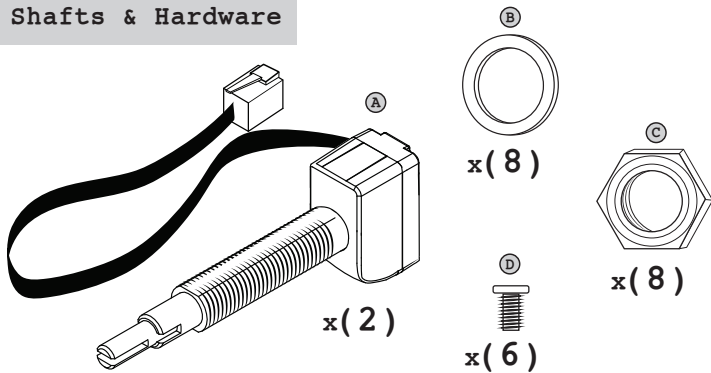

#### Additional Parts

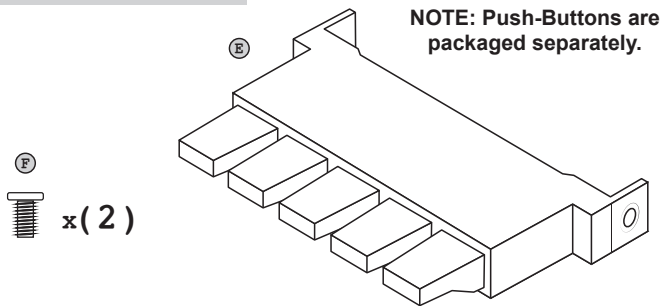

### Installation

- 1** Insert the Push-Buttons(E) into the Monterey Radio Face
- 2** Remove the two small clips attached to the Push-Buttons. Plug the attached wire from the Push-Buttons into the smaller receptor on the Radio Face.
- 3** Plug the ribbon cable from the Radio Motor into the Radio Face.
- 4** Attached the Radio Face assembly with the six small screws(D) located in the orange bag in the Radio Face box.
- 5** Attach InfinitiMount™ brackets with the eight screws from the Radio Motor box.
- 6** Insert control shafts(A).
- 7** Connect control shafts to Radio Motor.
- 8** Secure Radio Motor with backstrap.
- 9** Secure control shafts with shaft washers(B) and nuts(C), then install the front and rear knobs.

**Tip:** Refer to the Installation and Assembly Manual on our website for more comprehensive instructions.



Modern Sound For Your Classic

tech@retromanufacturing.com | help.retromanufacturing.com

### Control Layout

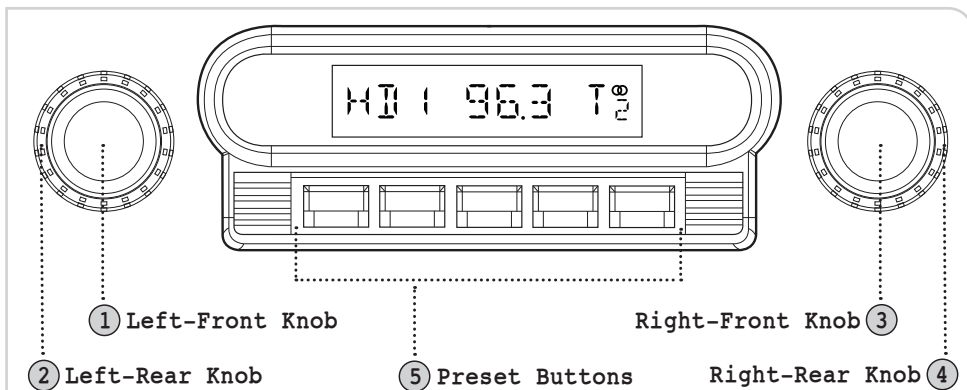

### Control Setup & Reset

By default, RetroSound® Radio Motors are configured to function with standard Radio Faces like the Monterey but can be configured to function with other RetroSound Radio Faces with alternate control layouts. If you have mistakenly changed your Radio Motor to use an alternate control layout, follow the steps below to reboot and change control modes back to the default settings.

With the vehicle's ignition on, press and hold the Left-Front Knob(1) for approximately 15 seconds to reboot the radio into the **SEL PANEL** menu. Once in the SEL PANEL menu, press and release the power button until the correct panel/control mode is displayed (select "Normal" for standard 2-shaft/push-button controls). Let the unit time out to accept the changes. The display will flash five times and reboot with the selected control mode activated.

### Radio Presets

#### Setting Radio Presets

To set a preset, tune to the station you want to set the preset to, and then press and hold the desired Preset Button(5) for two seconds.

#### Recalling Radio Presets

To recall a preset, simply press the Preset Button(5) your station was set to previously.

### Basic Operation

#### Power On/Off

Press the Left-Front Knob(1) to power the unit on.  
Press and hold the Left-Front Knob(1) to power the unit off.

#### Volume

Rotate the Left-Front Knob(1) to change the volume.

#### Changing Source Modes

Rotate the Left-Rear Knob(2) clockwise to cycle through the source modes.

#### Changing Radio Bands

Rotate the Right-Rear Knob(4) counter-clockwise to cycle through the radio bands.

#### Tune

Rotate the Right-Front Knob(3) to scroll through the stations.

#### Mute On/Off

Press the Right-Front Knob(3) to mute and unmute.

#### Equalizer (EQ)

Press the Left-Front Knob(1) to enter the Tone Control sub-menu. Press and release the Left-Front Knob(1) until you see the EQ setting you'd like to adjust. Rotate the Left-Front Knob(1) to adjust the setting. Press the Left-Front Knob(1) to move to the next item, and repeat to adjust each option. Let the unit time out to set.

#### Setting the Clock

Press and hold the Right-Front Knob(3) to enter the System Settings sub-menu. Rotate the Right-Front Knob(3) to cycle through the choices until you see CLK, then press the Right-Front Knob(3) to select. Rotate the Right-Front Knob(3) to adjust the hours. Then press the Right-Front Knob(3) again to move on to minutes. Rotate the Right-Front Knob(3) to adjust the minutes. Let the unit time out to set.

#### Display Color\*

Press and hold the Right-Front Knob(3) to enter the System Settings sub-menu. Rotate the Right-Front Knob(3) to cycle through the choices until you see SCAN, then press the Right-Front Knob(3) to cycle through the colors. Let the unit time out to set.

#### Beep On/Off

Press and hold the Right-Front Knob(3) to enter the System Settings sub-menu. Rotate the Right-Front Knob(3) to cycle through the choices until you see BEEP ON/OFF, then press the Right-Front Knob(3) to choose between BEEP ON or BEEP OFF. Let the unit time out to set.

\*Some features are not available on all radios.