



USER'S MANUAL

*RetroRadio*



MODERN SOUND FOR YOUR CLASSIC

Version 2

[www.retromanufacturing.com](http://www.retromanufacturing.com)

# TABLE OF CONTENTS

---

WELCOME..... 3

WHAT'S IN THE BOX..... 4

PRECAUTIONS..... 5

INSTALLATION INSTRUCTIONS..... 8

WIRING DIAGRAM..... 11

**OPERATING YOUR RADIO**

    BASIC OPERATION..... 14

    TONE CONTROLS..... 18

    SYSTEM SETTINGS..... 20

    USB/APPLE® DEVICE INSTRUCTIONS..... 25

    BLUETOOTH® INSTRUCTIONS..... 28

TROUBLESHOOTING..... 30

FREQUENTLY ASKED QUESTIONS..... 31

SPECIFICATIONS..... 34

LIMITED WARRANTY..... 35

REPLACEMENT PARTS..... 36

INSTALLATION NOTES..... 37

**Declaration of Conformity for San Diego/Motor 6**

Manufacturer:  
Retro Manufacturing, LLC  
7470 Commercial Way  
Henderson, NV 89011  
[www.retromanufacturing.com](http://www.retromanufacturing.com)  
U.S.A.



For more information visit [www.retromanufacturing.com/pages/declaration-of-conformity](http://www.retromanufacturing.com/pages/declaration-of-conformity)

## Made for iPod®

(Correct function of earlier versions cannot be guaranteed.)

- iPod Touch (5th generation): Ver. 9.3.5
- iPod Touch (4th generation): Ver. 6.1.2
- iPod Touch (3rd generation): Ver. 5.1
- iPod Touch (2nd generation): Ver. 4.2.1
- iPod Nano (6th generation): Ver. 1.1
- iPod Nano (5th generation): Ver. 1.0.2
- iPod Nano (4th generation): Ver. 1.0.4
- iPod Nano (3rd generation): Ver. 1.1.3
- iPod Classic (160 GB) (Late 2009): Ver. 2.0.4
- iPod Classic (120 GB): Ver. 2.0.1
- iPod Classic (80 GB, 160 GB): Ver. 1.1.2

## Made for iPhone®

(Correct function of earlier versions cannot be guaranteed.)

- iPhone SE: Ver. 10.1.1
- iPhone 6s Plus: Ver. 10.1.1
- iPhone 6s: Ver. 10.1.1
- iPhone 6 Plus: Ver. 10.1.1
- iPhone 6: Ver. 10.1.1
- iPhone 5s: Ver. 10.1.1
- iPhone 5: Ver. 10.1.1
- iPhone 4s: Ver. 9.3.5
- iPhone 4: Ver. 7.1.2
- iPhone 3Gs: Ver. 6.1.6
- iPhone 3G: Ver. 4.2.1

For clarity in identifying your model of iPod, please see Apple's document "Identifying iPod® models" at <http://support.apple.com/kb/HT1353>.

"Made for iPod®" and "Made for iPhone®" mean that an electronics accessory has been designed to connect specifically to iPod® or iPhone® respectively, and has been certified by the developer to meet Apple performance standards. Apple is not responsible for the operation of this device or its compliance with safety and regulatory standards. Please note that the use of this accessory with iPod® or iPhone® may affect wireless performance. Apple is not responsible for the operation of the device or its compliance with safety and regulatory standards.

iPod® and iPhone® are trademarks of Apple Inc., registered in the U.S. and other countries.

---

Sirius, XM, SiriusXM and all related marks and logos are trademarks of Sirius XM Radio Inc. All rights reserved.

---

Windows Media® and the windows logo are trademarks, or registered trademarks of Microsoft Corporation in the United States and/or other countries.

---

The Bluetooth® word mark and logos are owned by the Bluetooth® SIG, Inc., and any use of such marks by Retro Manufacturing, LLC are under license. Other trademarks and trade names are those of their respective owners.

# WELCOME

---

Thank you for purchasing a RetroSound® Retro Radio™. Motor 6 has the advanced features you expect from a modern car stereo. Your RetroSound® Retro Radio™ consists of two main parts: the radio face and the Motor 6 body.

## General Features

- Built-in DAB/DAB+ Tuner
- Made for iPod®/iPhone®/iPad®
- Charges Android devices
- Built-in Bluetooth® for hands-free calling and audio streaming
- Wireless Audio Browsing from your iPhone® or Android device
- Plays MP3, FLAC and WMA files via USB input
- Selectable 32,000 color LCD illumination with user presets
- AM/FM tuner with 30 presets and RDS
- Selectable international tuner frequencies
- Built-in amplifier (25 watts RMS/45 watts peak x 4 channels)
- 3 EQ presets plus user-controlled bass, mid-range, treble, fader, and balance adjustment
- InfiniMount shaft/bracket system for maximum installation flexibility
- Available with period-correct knobs and bezel
- Inputs: 2 rear-mounted standard USB ports and 2 rear auxiliary inputs
- Outputs: 6-channel pre-amp outputs (front, rear, subwoofer)
- Separate power antenna and amplifier turn-on lead(s)
- 2 year warranty

The information enclosed in this user's manual is to be used as a guide to assist you with installation and operation of your radio. This guide does not cover every installation possibility, vehicle, or every aspect of the installation process.

Retro Manufacturing, LLC, RetroSound®, or its subsidiaries, assume no responsibility for any installation. This manual may be updated from time to time.

Visit our website for the latest updates: [www.retromanufacturing.com](http://www.retromanufacturing.com).

# WHAT'S IN THE BOX

The items shown below are packaged with your Motor 6 box.



Main Wiring Harness  
(plugs into back of radio)



Power and Speaker  
Wiring Harnesses  
(both plug into Main  
Wiring Harness)



Motor 6 Radio Body



Bluetooth® Microphone



Metal Mounting Back Strap  
and Hardware



Plastic Washer Kit



InfiniMount Brackets



Bracket Mounting  
Hardware

The items shown below are packaged with your radio face box.



Radio Face



Radio Face  
Mounting Screws



Shaft Mounting Hardware



Shafts

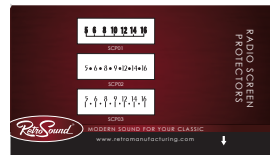

Vintage Radio Dial Screen Protectors  
(select models only)

# PRECAUTIONS

---

## PLEASE OBSERVE THESE PRECAUTIONS WHEN INSTALLING AND USING THIS UNIT:

This user's manual does not cover all possible installation scenarios. If you feel you can't install this unit yourself, take it to a local car audio professional. Feel free to contact us at [tech@retromanufacturing.com](mailto:tech@retromanufacturing.com) if you have questions about installing your radio.

- Do not disassemble or modify the unit or attempt to repair the unit yourself. If the unit needs to be repaired, consult your dealer or Retro Manufacturing, LLC.
- Do not use the unit when it is out of order. If the unit is out of order or is in an abnormal state (has foreign objects in it, is exposed to water, is smoking or smells), turn it off immediately and consult your dealer or Retro Manufacturing, LLC.
- Refer fuse replacement to qualified service personnel. When the fuse blows, eliminate the cause and have it replaced by a qualified service technician with the fuse prescribed for this unit. Incorrect replacement of the fuse may lead to smoke, fire and damage to the unit.
- If the unit does not turn on, check the connections first. Then check the fuse in your vehicle's fuse box and the fuse at the unit's wiring harness. Do not expose the unit to direct sunlight or excessive heat. Excessive heat will raise the interior temperature of the unit, which may damage it.
- Do not use the unit where it is exposed to moisture or dust. Exposure of the unit to moisture or dust may lead to smoke, fire or other damage to the unit and will void your warranty. Make sure the unit does not get wet in car washes or on rainy days.

# PRECAUTIONS

---

- Refer wiring and installation to qualified service personnel. Installation of this unit requires special skills and experience. For maximum safety, have it installed by your dealer or qualified service professional. Retro Manufacturing, LLC is not liable for any problems resulting from improper installation of the unit. Please be sure to follow the instructions carefully while attempting installation.
- Follow instructions to wire the unit. Failure to follow the instructions could cause damage to the unit, fire, injury or death.
- Be careful not to damage the leads. Prevent them from being caught in the vehicle chassis or from being damaged by screws or moving parts such as seat rails. Do not scratch, pull, bend or twist the leads. Do not install them near heat sources or place heavy objects on them. If leads must be routed around sharp metal edges, protect them by wrapping them with vinyl tape or similar protections.

**NOTE: Cutting the main wire harness, antenna lead, USB or auxiliary cables will void the warranty of your radio.**

- Use the designated parts and appropriate tools to install this unit. The use of parts other than those supplied may result in internal damage to the unit.
- Do not interfere with safety-related vehicle components. Do not wire or affix this unit to the fuel tank, brakes, suspension, steering wheel, pedals, etc. Check for electric wiring, piping and other items before installing the unit.
- Never install the unit in a location where it interferes with your field of vision.

# PRECAUTIONS

---

- Never splice into the power lead to supply other equipment with power.
- After installation and wiring, always check the normal operation of other electrical equipment.
- Make sure that no wires interfere with driving or getting in and out of the vehicle.
- Insulate all exposed wires to prevent short-circuiting or electric shock.
- Do not operate the unit for prolonged periods with the engine off. Prolonged operation with the engine turned off will drain the battery.
- To prevent accidents, keep the volume of your radio at a level that allows you to hear outside noises such as emergency sirens and train crossing warnings. Prolonged exposure to high volume levels may also result in hearing loss.
- This unit requires 12 volts to both the red and yellow power leads. The unit will not work without power to both of these leads.
- Disconnect the negative (-) battery cable before beginning installation. Verify the battery ground by checking that one wire is connected to the vehicle's starter mounting bolt or engine block and the other to the vehicle's chassis using at least 8 gauge wire. Make sure the alternator or generator connections are secure and free from corrosion, rust or dirt.
- This unit is designed for operation with a negative ground 12 volt DC battery system. Do not operate this unit with other battery systems, especially an 18 or 24 volt DC or a positive ground system. If you have a 6 volt system, you need to either convert to 12 volt DC or purchase a separate inverter that would increase the voltage to 12 volts.

**NOTE:** The inverter needs to be rated at 10 amps or higher in order for the radio to operate properly.



# INSTALLATION INSTRUCTIONS

---

## STEP 1: Install the Radio Face

Plug the ribbon cable included with the Motor 6 body into the radio face. After plugging in the face, attach it to the body and tighten with the four radio face mounting screws provided in the radio face box (the screws are very small and are in the hardware bag with the shaft nuts).

The RetroSound® logo on the Motor 6 body should be facing upwards. Take care to not install the face to the body upside down.

**NOTE:** Optionally, the radio face can be mounted remotely up to nine feet away from the Motor 6 body using an optional Face to Body Extension Cable (sold separately). In some installation applications, a bracket can be used to mount the face to the body at an angle.

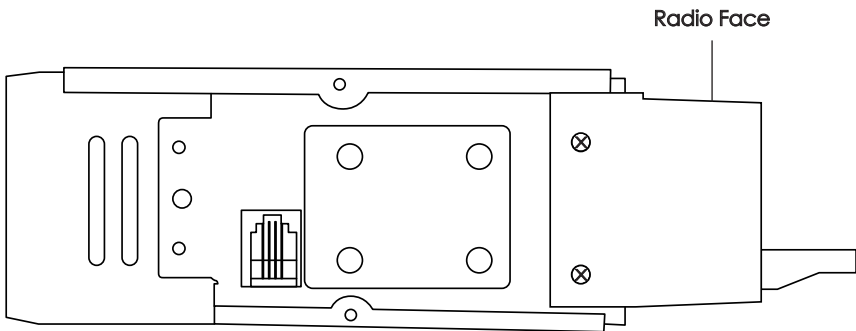

Figure 1 - Attach the Radio Face

# INSTALLATION INSTRUCTIONS

---

## STEP 2: Install InfiniMount Brackets

Attach each InfiniMount bracket to the correct side of the radio using the supplied screws. Before tightening the screws, you need to adjust the brackets up, down, forward or backward. You may also rotate, cut, or bend the brackets to achieve the perfect fit (See Figure 2). Complete the assembly with at least two screws tightened on each side.

**NOTE:** In some installations the brackets must be moved far enough forward or backwards or rotated so that only two screws will align with the threaded screw holes on the radio. Two screws are sufficient to hold the brackets in place.

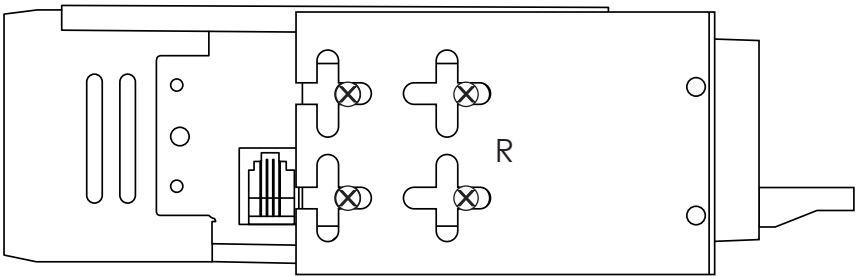

**Figure 2 - Attach InfiniMount Brackets**

**NOTE:** You may need to cut, trim or bend the brackets to achieve a perfect fit. You can even drill new mounting holes into the bracket if you need to. The InfiniMount system is designed to be modified. Modifying your brackets will NOT void your warranty.

# INSTALLATION INSTRUCTIONS

## STEP 3: Mount InfiniMount Shafts to Brackets

To match the location of your shafts to the proper width of your vehicle's dash, first measure the distance between your existing shaft holes from center to center.

Mount a shaft to each bracket using the supplied shaft nuts and washers. Finger tighten the shaft nuts to prepare for the final installation (See Figure 3). Once you ensure proper width, tighten the screws and nuts (DO NOT OVERTIGHTEN).

**DAMAGE FROM OVERTIGHTENING WILL VOID YOUR WARRANTY.**

Finally, plug the shafts into each side of the main unit (See Figure 4).

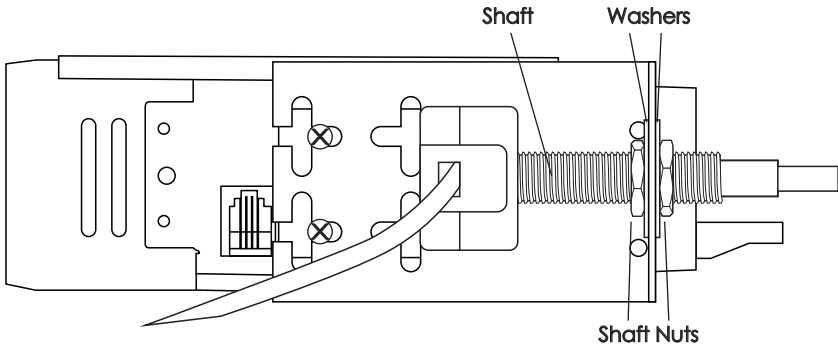

**Figure 3 - Mount Shafts to Brackets**

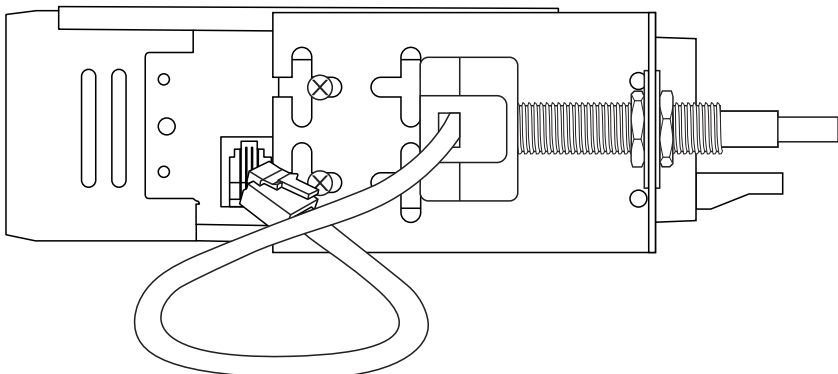

**Figure 4 - Plug Shafts into the Body**

# INSTALLATION INSTRUCTIONS

## STEP 4: Complete Wiring Connections

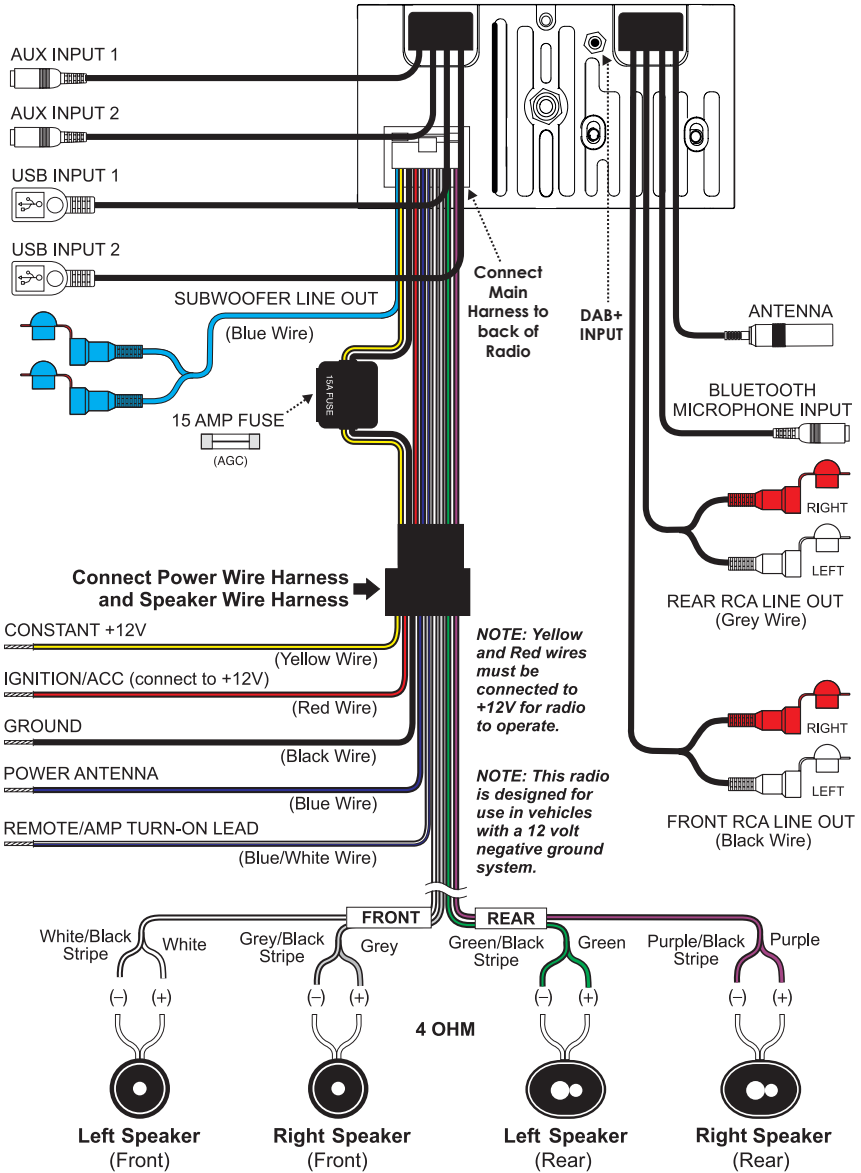

Figure 5 - Wiring Diagram

NOTE: Cutting the wiring harness, antenna lead or auxiliary cable will void your warranty.

# INSTALLATION INSTRUCTIONS

---

**NOTE: This unit requires +12 volts to both the red and yellow wires to operate properly.**

Locate the three wiring harnesses: main wiring harness, power wiring harness and speaker wiring harness (see "What's in the Box" on page 4). First connect the main wiring harness to the back of the radio body. Then connect both the power and speaker wiring harnesses to the black female plug of the main wiring harness.

Next, connect the bare wire ends of your power and speaker wires to the appropriate power and speaker locations in your vehicle (see Figure 5). Have your radio installed by a professional if this part of the install is too difficult, or contact us if you have questions.

## Bluetooth® Microphone

Your Bluetooth® microphone enables you to place hands-free phone calls through your radio. The Bluetooth® microphone input is located at the rear of the radio body. To use your Bluetooth® microphone, you will need plug it into the plug at the rear of the radio body and route it to an accessible location such as the A-pillar or the steering column.

## Rear Auxiliary (AUX) Inputs

Two auxiliary inputs are located at the rear of the radio body. These auxiliary inputs allow you to listen to any external source with a standard headphone output. An example of an external source would be a MP3 player, iPod® or iPhone®, portable CD player or portable satellite radio receiver.

**NOTE: If the auxiliary cables provided are not long enough, you may use our USB/AUX Extension Cable (sold separately) to extend the reach of one cable. This cable also allows the installation of one USB and auxiliary port into the factory location of the cigarette lighter for a factory look and easy access. A male to male 3.5mm auxiliary cable is required to connect your device to the auxiliary port on your radio.**

# INSTALLATION INSTRUCTIONS

---

## Rear USB Inputs

Two USB connector cables are located at the rear of the Motor 6 radio body. During installation, you must route the cables to a convenient and accessible location for plugging in USB devices. If the cables provided are not long enough, you may use our optional USB/AUX Extension Cable (not included) to extend the reach of the cable. This cable also allows you to install the USB/AUX port into the factory location for the cigarette lighter for a factory look and easy access.

## DAB/DAB+ Input

The DAB+ input is the brass connection located at the rear of the radio body. A special antenna is required to listen to DAB and DAB+ digital audio broadcasts (see page 11).

## STEP 5: Finish the Installation

**IF USING A BEZEL**, Place the bezel on the face of the radio, then install the assembled radio from behind the dash until the bezel and radio face are flush with the front of the dash and the radio shafts protrude through the shaft openings in the dash. Using the supplied washers and shaft nuts (see “What’s in the Box” on page 4), secure the radio to the dash.

**IF USING A FACEPLATE**, slide the radio into the hole from behind the dash, then align the faceplate over the radio shafts from the front. Using the supplied washers and shaft nuts (see “What’s in the Box” on page 4), secure the faceplate to the dash and the radio.

## **DAMAGE RESULTING FROM OVERTIGHTENING THE SHAFT NUTS WILL VOID YOUR WARRANTY.**

Next, you'll need to secure the rear of the radio using the supplied back strap and hardware (See “What’s in the Box” on page 4). The back strap mounts using the threads in the rear of the radio body and can be bent and adjusted to align with the mounting point of the original factory radio behind the dash.

# INSTALLATION INSTRUCTIONS

---

THE SHAFTS ARE NOT STRONG ENOUGH TO SUPPORT THE WEIGHT OF THE RADIO. FAILURE TO SECURE THE RADIO WITH THE BACK STRAP CAN DAMAGE YOUR SHAFTS AND WILL VOID YOUR WARRANTY.

Figure 6 - Installing the Back strap

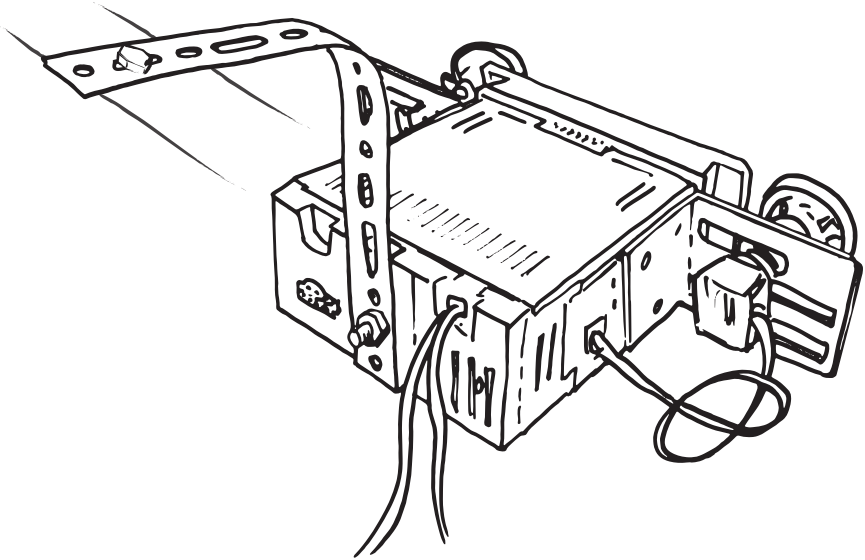

View from behind dash

Finally, slide the rear knobs over the shafts, rotating them into the correct position, and push them into place. Mount the front knobs by gently pressing them onto the shaft.

**DO NOT PRESS TOO HARD. PRESSING TOO HARD CAN DAMAGE YOUR SHAFTS AND WILL VOID YOUR WARRANTY.**

# OPERATING YOUR RADIO

---

## Basic Operation

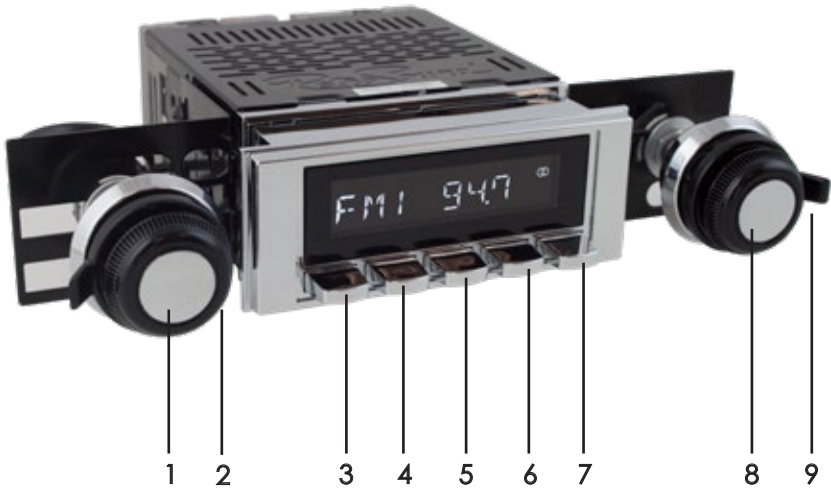

Figure 7 - Front Panel Controls

- 1. Left Front Knob
- 2. Left Rear Knob
- 3. Push-Button
- 4. Push-Button
- 5. Push-Button
- 6. Push-Button
- 7. Push-Button
- 8. Right Front Knob
- 9. Right Rear Knob

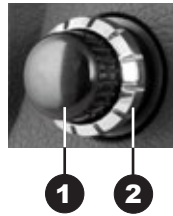

Figure 8 - Left Shaft with Knobs



## General Operation

### Power On/Off

Press the left front knob (#1) to turn the unit on.

RETRO SOUND will appear on the screen.

Press and hold the left front knob (#1) to turn the unit off.

GOODBYE will appear on the screen to confirm that it has turned off.

### Volume

Rotate the left front knob (#1) to adjust the volume between 0-46.

### Source Mode

Rotate the left rear knob (#2) clockwise to select from available listening sources: AUX-1, AUX-2, USB-1, USB-2, BT AUDIO, AM/FM, DAB/DAB+.

(The USB source modes will not appear unless a USB device is plugged in).

The auxiliary and USB inputs are located at the back of the radio body. The auxiliary inputs may be used to play music from any portable device with a standard headphone output, such as a MP3 player, iPod® or iPhone®, portable CD player or portable satellite radio receiver. The USB inputs allow you to control iPod®/iPhone® or play music from a flash drive. To use these inputs, the cables must be routed to an accessible area during installation.

### Radio Tuning

Rotate the right front knob (#8) to tune to the next or previous AM/FM frequency or DAB/DAB+ channel.

**NOTE:** When the radio is tuned to a strong stereo FM station, the stereo indicator will appear on the upper right corner of the LCD screen (two oval circles).

# OPERATING YOUR RADIO

---

## Radio Bands

Rotate the right rear knob (#9) counter-clockwise to toggle through five radio bands (two AM and three FM).

## Storing Radio Presets

There are six radio presets for each radio band. For presets one through five, tune to the desired radio station and then press and hold the push-button (#3-7) to store into memory. To store preset number six, tune to the station you want to store, then rotate and hold the right-rear knob clockwise to store.

## Selecting Radio Presets

To recall radio presets, press the appropriate preset button (#3-7) in the selected radio band. To recall preset six, rotate the right rear knob (#9) clockwise and release it.

## Mute

Press the right-front knob (#8) to mute or unmute.

---

## DAB-Digital Audio Broadcasting

This radio has a built-in DAB+ tuner that is compatible with both DAB and DAB+ digital radio broadcasts. While technically these two use different encoding (MP2 for DAB and AAC Plus for DAB+) either way the digital broadcast signal resists multi-path interference offering CD-quality audio with more fidelity and reduced noise compared to analog.

A special DAB antenna is required to listen to DAB and DAB+. RetroSound® offers an optional antenna adapter (sold separately) that allows you to convert any standard AM/FM antenna to receive DAB/DAB+ signals (ask for our model DAB-1).

## tone controls

This sub-menu allows advanced tonal adjustments, balance and fader controls and the preset equalizer options. To access this sub-menu, press the left front knob (#1). Keep pressing the left front knob to scroll through the available options. To adjust within the sub-menu, rotate the left front knob clockwise or counter-clockwise.

### Digital Signal Processor (DSP)

This sub-menu allows you to turn the Digital Signal Processor (DSP) on and off. Factory default is **DSP OFF**. When set to **DSP ON**, you can choose one of three preset equalization settings:

- **CLASSIC** This setting offers subtle sonic adjustments that lend themselves to classical music.
- **POP** This setting accentuates bass and treble frequencies and is suitable for popular music.
- **ROCK** This setting accentuates treble frequencies and is suitable for rock music.

### Bass

This sub-menu (**BASS**) allows bass tone adjustments. You may boost or cut low frequencies from +7 to -7.

### Middle

This sub-menu (**MIDDLE**) allows mid tone adjustments. You may boost or cut mid frequencies from +7 to -7.

### Treble

This sub-menu (**TREBLE**) allows treble tone adjustments. You may boost or cut high frequencies from +7 to -7.

# OPERATING YOUR RADIO

---

## Balance

This sub-menu (**BAL**) allows adjustment of stereo sound to left or right. This may be helpful in compensating for the position of the driver in relation to the vehicle's speakers. Adjustment range is from 0-12 between left and right speakers.

## Fader

This sub-menu (**FADER**) allows you to adjust the sound between the front and rear speakers. Adjustment range is from 0-12 between front and rear speakers.

## XBAS

This sub-menu (**XBAS**) boosts bass and treble for listening at low volumes. This should only be used at low volume levels and should be set to **XBAS OFF** at high volumes.

## Subwoofer ON/OFF

This sub-menu (**SUB**) turns the subwoofer RCA output on or off.

## Subwoofer Volume

This sub-menu (**SUB VOL**) adjusts the volume of the subwoofer between 0-12. This sub-menu will only appear when a subwoofer is attached and **SUB ON** is selected in the previous menu.

## Subwoofer Crossover Frequency

This sub-menu (**SUB FREQ**) allows adjustment of the frequency crossover point of the subwoofer between 80Hz, 120Hz or 160Hz.

## Bass Crossover Frequency

This sub-menu (**BAS FREQ**) allows adjustment of the frequency crossover of the bass signals between 60Hz, 80Hz, 100Hz or 200Hz.

## Middle Crossover Frequency

This sub-menu (**MID 1.0K**) allows adjustment of the frequency crossover of the mid signals between 0.5KHz, 1.0KHz, 1.5KHz or 2.5KHz.

## Treble Crossover Frequency

This sub-menu (**TRE 10.0K**) allows adjustment of the frequency crossover of the treble signals between 10.0KHz, 12.5KHz, 15.0KHz or 17.5KHz.

## SYSTEM SETTINGS

The System Settings sub-menu system enables access to the numerous additional features of your radio. Press and hold the right front knob (#8) for three seconds to access the sub-menu system. Then rotate the right front knob (#8) to scroll through the available sub-menu options. Once in a specific sub-menu, press the right front knob to change options.

### Auto Seek/Manual

This sub-menu allows you to select either **AUTO SEEK** or **MANUAL** tuning when listening to the radio. In Auto Seek mode the radio will tune to the next available station when tuning.

### A Store

This sub-menu will automatically fill FM presets on all three FM bands of six presets each (eighteen total presets) with the strongest stations. To activate this feature, once in the system settings, rotate the right front knob (#8) until **A STORE** appears on the screen, then press the right front knob (#8) to activate. This process can take up to one minute.

# OPERATING YOUR RADIO

---

## Local/Distant

This sub-menu changes the sensitivity of the FM tuner. When listening to the FM tuner, selecting between **LOCAL** and **DISTANT** can aid in listening to weak FM stations or compensate for stations that have too strong a signal.

## Clock

This sub-menu allows you to set the clock. To adjust hours, select **Clock** and press the right front knob (#8). Then rotate the right front knob (#8) to adjust. Adjusting past 12 will toggle the AM/PM indicators. Once the hour is set, press the right front knob (#8) to switch to minutes. Set the minutes by rotating the right front knob (#8). Once the minutes are set, press the right front knob (#8) to access the 12/24 menu.

## Clock 12/24

This sub-menu allows you to adjust the clock from a twelve hour clock to a twenty-four hour clock. The factory default setting is for a twelve hour clock (**CLK 12**).

## Display Frequency/Clock

This sub-menu allows you to adjust the priority screen view between radio frequency (**DISP FREQ**) and clock (**CLK**).

## Clock ON/OFF

This sub-menu allows you to turn off the clock when the radio is off. Default is **CLK ON**.

## Beep On/Off

This sub-menu controls the audible beep confirmation that sounds during operation of the radio. Select **BEEP ON** to hear the audible beep, and **BEEP OFF** to disable the audible beep.

## Display Color (SCAN)

This sub-menu allows you to change the display color.

To customize your own display color, look for the word **SCAN** in the sub-menu, then click the right front knob (#8) until **USER** is selected in the preset color menu. Rotate the right front knob (#8) clockwise once. You should now see **RGB**. This will allow you to edit the RGB values for 32,000 color variations. Press the knob (#8) to select the reds and rotate to adjust. Once a color is selected, press the same knob (#8) to move to the greens. Repeat this process to adjust the greens and the blues.

**WARNING: Do not set all RGB settings to "00." Doing so will turn the display off. Resetting your radio by disconnecting the power will NOT reset the display.**

## Dimmer High/Low

This sub-menu allows you to adjust the radio's display brightness between high (**DIMM HIGH**) and low (**DIMM LOW**).

## Radio Data System (RDS) ON/OFF

This sub-menu allows you to turn on or off the RDS function. The default is **RDS ON**.

RDS tuners can automatically tune in stations according to the style of music (or talk) they broadcast. Some RDS tuners can even break in with traffic alerts or emergency broadcasts.

RDS enables your receiver to display text messages (usually call letters and format info) that many FM stations include on a sub-carrier signal within their normal broadcast signal.

The RDS function is always active, and if the FM station you are listening to is broadcasting RDS information, the radio station call letters, song info, artist info and other messages will appear. Not all FM stations use RDS nor will all RDS functions work on every station.

# OPERATING YOUR RADIO

---

## Program Type (PTY)

This sub-menu only works in Europe (**AREA EUR**) and allows you select up to 31 pre-defined program types allowing you to find similar programming by genre.

To change your program type, first make sure the tuner is set to **AREA EUR**. Then cycle through the sub-menu system until you see **PTY**. Now press the right front knob (#8) to activate, then rotate the right front knob (#8) to select from the program type list. Once the program type is selected, press the front right knob (#8) to activate.

Now you will see **PTY SEEK** on the screen which indicates that the radio is searching the FM band for stations with your selected program type. If none are found, you will see **NONE FOUND** on the screen, and it will revert back to the last station selected.

## Alternative Frequency (AF) ON/OFF

This sub-menu allows the radio to automatically search for another frequency that provides the same station when the signal gets weak.

## Traffic Announcements (TA) ON/OFF

This sub-menu allows you to turn the traffic announcements feature on or off. The traffic announcements function is part of RDS and allows FM stations to broadcast traffic announcements that scroll across the screen or audible traffic alerts to your radio. Simply press the right front knob (#8) to toggle between **TR ON** or **TR OFF** and allow the display to time out to enable your choice.

## Clock Time (CT) ON/OFF

This sub-menu allows you to turn the clock time feature on or off. If the radio station supports clock time, your radio will synchronize its clock with the radio station's clock.



## Bluetooth® ON/OFF (BT)

This sub-menu turns Bluetooth® on or off. Bluetooth® must be enabled in order to connect a Bluetooth® device for hands-free operation or streaming audio.

## Bluetooth® Connect/Disconnect

This sub-menu allows the radio to be discoverable on your Bluetooth® device. Choose **BT CONNCT** to allow your device to connect, and **BT DISCON** to disable Bluetooth® connections.

To connect your device, choose **BT CONNCT**, then search for “RETROSOUND” in your phone’s Bluetooth® device list. Enter password “0000” if prompted.

## Area EUR/AUS/JAP/RUS/USA

Motor 6 has the capability to receive radio broadcasts from around the world. This sub-menu allows you to adjust to broadcasts in your country. Factory default setting is Europe (**EUR**). Press the right front knob (#8) to toggle between Australia (**AUS**), Japan (**JAP**), Russia (**RUS**), and United States (**USA**). To confirm the change, pause to let the sub-menu revert to your tuner or move onto the next menu item. You will see your selected tuner mode: **AREA EUR**, **AREA AUS**, **AREA JAP**, **AREA RUS**, **AREA USA**.

## Volume Last/Adjust

This sub-menu allows you to adjust the volume level that the radio first turns on to. The factory default setting is **VOL LAST**, which sets the turn on volume at the last volume used. **VOL ADJUST** allows you to preset the volume level that the radio turns on at from 0-46.

# USB DEVICE INSTRUCTIONS

---

## Connecting a USB Device

The USB 1 and USB 2 inputs are located at the rear of the radio body. The USB cables must be routed to a convenient and accessible location for plugging in USB devices.

Once you've turned on your radio and connected your flash drive, iPod®/iPhone® or supported USB device to the USB input, the radio will find your songs and automatically begin playing them.

The **USB** icon appears on the LCD during USB playback.

To change songs, rotate the right front knob (#8) to access the next or previous song. The preset buttons on the front of the radio's control face (#3-7) will allow you to play/pause (#3), listen to 10 seconds of each song (INT) (#4), repeat the track you're listening to (RPT) (#5) or randomly select from all songs on the attached flash drive or supported USB device (RDM) (#6).

## About MP3/WMA/FLAC Files

MP3 (MPEG Audio Layer-3), FLAC (Free Lossless Audio Codec) and WMA (Windows Media Audio) is a format for compressed audio files. When your radio is in USB mode (USB 1 or USB 2), you can play MP3 and unprotected (no DRM) WMA files off the flash drive.

## Common facts about these compressed-sound formats:

- High bit rate and high sampling frequencies are recommended for high sound quality.
- Selecting VBR (Variable Bit Rate) is not recommended because playing time is not displayed properly and there may be some audible skipping artifacts. The playback sound quality differs depending on the encoding circumstances. For details, refer to the user manual of your encoding software.
- When adding MP3 files to your flash drive, it is recommended to set the bit rate to 128 kbps or more and "fixed."
- When adding WMA files to your flash drive, it is recommended to set the bit rate to 64 kbps or more and "fixed." Do not set the copy protect attribute on the WMA file or you will not be able to play the track.

# USB DEVICE INSTRUCTIONS

---

- Motor 6 will read only FAT32 formatted flash drives. This radio will NOT read NTFS formatted drives.
- Motor 6 will read files placed in the root directory first before playing files in the folder structure of the drive. Please note that files are read in order of creation NOT alphabetically or numerically. Older files will get read first in a folder.

Caution! Except for private use, duplicating audio data (including MP3/WMA) or distributing, transferring or copying it, whether free or paid for without permission of the original copyright holder is strictly prohibited by law and international treaty.

## Viewing MP3/WMA Song Information

When playing MP3/WMA files from the USB source, you can view the track name, album, artist info (ID-3) information automatically from these files. Once the USB drive is inserted, the following info will scroll across the screen in the following order: **F-DIR** (folder directory), **MP3 FILE** (file name of song), **ALBUM** (name of album) **ARTIST** (name of artist), **SONG** (name of song).

To access the clock when in USB mode, rotate the left rear knob counter-clockwise. The clock will time out after a few seconds and will revert to the ID-3 information. Turning the left rear knob counter-clockwise again will revert to viewing the ID-3 information on-screen.

# USB DEVICE INSTRUCTIONS

---

## USB Playback Mode

The preset buttons (#3-7) on the front of the radio's control face will allow you to play/pause, listen to 10 seconds of each song (INTRO), randomly shuffle all songs (RDM) and navigate folders.

To play or pause, press button (#3).

To activate/deactivate scan, press button (#4).

To activate/deactivate shuffle, press button (#5).

To go to the previous folder, press button (#6).

To go to the next folder, press button (#7).

To switch to the next song, rotate the right front-knob (#8) clockwise.

To switch to the previous song, rotate the right-front knob (#8) counter-clockwise.

To activate/deactivate repeat, rotate the right rear knob (#9) clockwise.

# BLUETOOTH® DEVICE INSTRUCTIONS

---

## Bluetooth® Instructions

### Bluetooth® Hands-Free and A2DP Streaming Operation

You can make or receive phone calls using a Bluetooth® enabled phone connected to your radio, controlling basic functions via the radio interface. During a call, the radio music source will be muted and the call broadcast through your car speaker system. You can also listen to music and browse folders stored on a A2DP enabled Bluetooth® device.

### Pairing a Bluetooth® Device

When connecting a Bluetooth® device for the first time, you must first pair the device with the unit. For most devices, pairing only needs to be done once.

1. To pair your device first make sure the Bluetooth® function is turned on in the radio sub-menu.
2. Then, change the **BT DISCON** function to **BT CONNED** to make your radio discoverable (ensure Bluetooth® is enabled on your device).
3. Next, search for a new Bluetooth® device from the phone (this may take up to 30 seconds) and select "RETROSOUND" from the Bluetooth® device list.
4. If prompted, enter "0000" for the PIN. If successful, "PAIRING OK" will be displayed on the LCD screen.

The paired device will then connect to your radio automatically.

On some devices, you may need to select "SET AS AUTHORIZED" or similar to ensure your radio will automatically pair on future usage.

**PAIRED NOTIFICATION DISPLAY:** When the Bluetooth® device is paired with your radio, the Bluetooth® icon will appear on the LCD screen. This will occur whenever you use the system while the paired device is within range.

# BLUETOOTH® DEVICE INSTRUCTIONS

---

## Placing a Call

1. Dial the desired number on the paired phone.
2. Once dialing is in progress, **CALLING** will appear on the screen.
3. Once the call is in progress, **TALK** will appear on the screen along with the elapsed call time (**TALK 00:00**).

## Receiving a Call

1. If a call is incoming, any audio playback from the current source will either be muted or paused (depending on the source) and **PHONE IN** will be shown on the screen along with the caller ID if it is enabled by the phone/carrier.
2. To accept the call, rotate the left-rear knob (#2) counter-clockwise.

## Ending a Call

1. To end the call, rotate the left rear-knob (#2) counter-clockwise.

**NOTE:** We recommend mounting the microphone on the sun visor, A-pillar or steering column inside the vehicle close to the driver. The microphone is very sensitive, and you may speak at normal volume when using hands-free operation.

## Streaming Music From Your Device

2. Once your device is paired with your radio, make sure the source mode is set to **BT AUDIO**.
3. Next, select your desired playback source on your device (iTunes®, Pandora®, etc) and play the music as you normally would.

**NOTE:** Some devices may allow your radio the ability to skip songs/tracks/selections or browse folders by using the right front knob (#8).

# TROUBLESHOOTING

Problem	Possible Cause	Action to Solve Problem
Radio will not turn on (no lights, no sound)	12 volt Batt+ wire not connected or incorrect voltage	Check all connections for proper voltage with a volt meter. Voltage range: 12-15 volts
	+12 volt accessory wire not connected or incorrect voltage	Check +12 volt accessory wire connection
	Ground wire not connected	Check ground connection
	Fuse on Batt+ is blown	Replace blown fuse
No sound heard from unit but unit lights up	Volume turned all the way down	Increase radio volume
	Internal amp in protection mode	Check speaker leads for any grounded or shorted wires
	Wrong source mode selected	Make sure the unit is in the desired source mode ( <b>RADIO, AUX 1, AUX 2, USB 1, USB 2, DAB</b> )
Unit blows fuses	Possible short in wiring	Incorrect fuse used, make sure only fuses with correct 15 amp ratings are used and check all wiring connections for possible short
	Battery hooked up backwards	Make sure battery is properly connected
USB Error	Invalid media / device type	Please review page 25 for which formats and devices are acceptable for playback

## System Reset

To restore/reset the unit to factory defaults, remove all power from the unit, wait at least 2 minutes and then reconnect power. Resetting your unit will not remove your station presets or reset your display color, but it will reset the clock.

# FREQUENTLY ASKED QUESTIONS

---

## **Do your radios work on 6 volt systems or on positive ground systems?**

No. Our radios are 12 volt, negative ground only. After-market converters and inverters are available but must have at least 10 amps of continuous output.

## **I'm having problems getting the radio to turn on.**

RetroSound® radios require 12 volts to both power leads. The red lead (+12 volt accessory) goes to a switched power source, and the yellow to a constant +12 volt power source. Using a volt meter, check the voltage when the key is turned from "off" to "on". If there is a significant drop in the voltage, the circuit the yellow lead is attached to cannot handle the additional draw of the radio. You will need to find another circuit that can handle the additional draw of the radio, or you will need to go directly to the battery.

## **What speaker wire do you recommend I use?**

We recommend using 16 gauge wire for the speakers..

## **I have all 4 speakers connected to your radio and the display is lit up like it is working, but there's no sound coming out.**

This usually indicates one of two things:

- Speaker wires touching each other or the vehicle chassis at some point. Check each speaker lead from radio to speaker.
- Speaker impedance below 4 ohms. Older speakers are usually not compatible with modern electronics.



# FREQUENTLY ASKED QUESTIONS

---

**My car originally came with a switch to control my automatic antenna. Can I use the RetroSound® radio's remote antenna wire to control my antenna?**

No you cannot. Your factory antenna is known as "semi-automatic." It requires a switch to either extend or retract the antenna. You must retain this switch to control your antenna; the RetroSound® radio's power antenna wire is for more modern "fully-automatic" antennas not requiring a separate switch.

**The sound output is all mid-range, with very little bass and a strangled-sounding upper range. What is wrong?**

One of your speaker wires is connected backwards. This is called being "out of phase." Check to make sure positive is wired to positive and negative to negative on all your speakers.

**Will cutting or bending the InfiniMount brackets void the warranty or harm the unit?**

No. The RetroSound® patented InfiniMount bracket system has been designed specifically to be bent, cut and modified to simplify radio installation. Modification to the radio's brackets is actually encouraged to ensure proper fit.

If you have questions about modifying the bracket system, feel free to contact us.

**How much should I tighten the shaft nuts when installing the brackets and mounting the radio to the dash?**

**DO NOT OVERTIGHTEN** the shaft nuts. The shaft nuts are **NOT** the only means of securing the radio to the dash. There is a back strap included which works with the shaft nuts to secure the radio to the dash. Please note that overtightening the shaft nuts could break the shafts. Retro Manufacturing, LLC will not be responsible for broken shafts due to overtightening of the shaft nuts.

# FREQUENTLY ASKED QUESTIONS

---

**I have your radio with an amp connected, but hear a whining/buzzing sound through the speakers when I step on the accelerator.**

If you have an external amplifier installed and experience a high-pitched noise that varies with the engine's RPM, there are many possible solutions:

- Make sure the amplifier's gain controls are not turned all the way up. Amplifiers amplify everything, including noise.
- Try grounding the amplifier near where it is installed.
- Try a filter on the amplifier's 12 volt power lead. Make sure to use a filter that includes a ground wire.
- On rare occasions, noise can be introduced through the antenna lead. If disconnecting the antenna makes the noise go away, you need to replace or repair the antenna plug where it goes into the radio.

**When I plug in my flash drive the screen says **USB ERR**, and it won't play the files I placed on the drive.**

- Make sure the files on the drive are .mp3, flac or unprotected .wma (Windows Media Audio) files. iTunes files are .m4a format and need to be converted to .mp3 format, which can easily be done using iTunes.
- Verify the capacity of the flash drive. Motor 6 will only play 1 gig up to 32 gig size flash drives.
- Make sure the flash drive is not NTFS formatted. Always use the FAT32 format (most drives are formatted with FAT32 from the factory). Be sure to do a full format rather than a quick format, and check that none of the files or folders have names longer than 64 characters. It is very important that none of the audio files have DRM. Use only MP3 files or unprotected Windows Media format files.

# SPECIFICATIONS

---

## FM

Tuning Range (international tuning capable) with RDS.....	87.5-107.9MHz
Antenna Terminal.....	External Antenna Connector
Usable Sensitivity.....	12.5 dBs
Selectivity.....	75 dB @ 400kHz
Signal to Noise Ratio.....	62 dB (Stereo), 67 dB (mono)
Harmonic Distortion @ 1 kHz.....	0.8% (stereo), 0.5% (mono)
Separation.....	32 dB @ 1kHz
Frequency Response.....	30-16,000Hz

## AM (EU and US Tuning Capable)

Tuning Range (international tuning capable).....	530-1710 kHz
Antenna Terminal.....	External Antenna Connector

## Digital Audio (DAB/DAB+)

Tuning Range.....	174.9mHz-239.2mHz
Antenna Terminal.....	DAB Antenna Connector

## General

Dimensions (radio face & push-buttons only).....	3.5"W x 1.5" H x 1.05" D
Dimensions (radio body).....	3.96"W x 1.98"H x 4.30"D
Power Requirements.....	10.5-14.4 volts
Current Consumption (during operation).....	Max. 15A
Current Consumption (car off).....	<3.5 mA
Output Power (@ 14.4 volts @ 4 ohm @ 1% THD).....	25x4 watts RMS / 45x4 watts Max Power
Output Impedance.....	4-8ohm
Low Level Output (4 channels).....	2.85 volts
EROM.....	Non-Volatile Memory
AUX 1 Input (AUX cable length, 8").....	>300 mV / 6 kΩ
AUX 2 Input (AUX cable length, 8").....	>300 mV / 6 kΩ
USB 1 Input (USB cable length, 40").....	.5V (USB female input)
USB 2 Input (USB cable length, 40").....	.5V (USB female input)
Fuse.....	15amp AGC

**NOTE: All specifications are subject to change without notice.**

# LIMITED WARRANTY

---

## Limited Warranty

If your unit does not work properly because of defects in materials or workmanship, Retro Manufacturing, LLC (collectively referred to as "the warranter") will for the length of the period indicated in the chart below at its option either (a) repair your unit with new or refurbished parts, or (b) replace it with a new or refurbished unit. The warranty period starts with the date of original purchase. The decision to repair or replace will be made by the warranter.

CATEGORIES	WARRANTY
Motor 6 Radio	Two (2) Years

During the warranty period, there will be no charge for parts. You must mail in your unit prepaid during the warranty period. This warranty only applies to products purchased and serviced in the United States or Puerto Rico. This warranty is extended only to the original purchaser of a new product which was not sold "as is."

A purchase receipt or other proof of the original purchase date is required for warranty service.

To handle a warranty issue, contact us at [tech@retromanufacturing.com](mailto:tech@retromanufacturing.com) or 702.483.2222 for a Return Authorization (RA) number. All returns and warranty issues must be accompanied by a Return Authorization number. Any product received without a RA number will be refused.

### LIMITED WARRANTY-LIMITS AND EXCLUSIONS

This warranty ONLY COVERS failures due to defects in materials or workmanship, and DOES NOT COVER normal wear and tear or cosmetic damage. The warranty ALSO DOES NOT COVER damages which occurred during shipment, failures which are caused by products not supplied by the warranter, failures which result from accident, misuse, abuse, neglect, bug infestation, mishandling, misapplication, alteration, faulty installation, set-up adjustment, maladjustment of consumer control, improper maintenance, improper antenna, inadequate signal reception or pickup, power line surge, improper voltage supply, lightning, modification, commercial use (such as use in hotels, offices, restaurants, or other business uses) or rental use of the product, or service by anyone other than Retro Manufacturing, LLC, or damage that is attributable to acts of God.

THERE ARE NO EXPRESS WARRANTIES EXCEPT AS LISTED UNDER "LIMITED WARRANTY". THE WARRANTER IS NOT LIABLE FOR INCIDENTAL OR CONSEQUENTIAL DAMAGES RESULTING FROM THE USE OF THIS UNIT, OR ARISING OUT OF ANY BREACH OF THIS WARRANTY. (As examples, this excludes damages for lost time, cost of having someone remove or re-install an installed unit if applicable, travel to and from the servicer, and loss of media, data or other memory contents. The items listed are not exclusive, but are for illustration only.) ALL EXPRESS AND IMPLIED WARRANTIES, INCLUDING THE WARRANTY OF MERCHANTABILITY, ARE LIMITED TO THE PERIOD OF THE LIMITED WARRANTY.

Some states do not allow the exclusion or limitation of incidental or consequential damages, or limitations on how long an implied warranty lasts, so the exclusions may not apply to you. This warranty gives you specific legal rights and you may also have other rights which vary from state to state. If a problem with this unit develops during or after the warranty period, you may contact your dealer or Retro Manufacturing, LLC.

# REPLACEMENT PARTS

---

If you need replacement parts, contact us at sales@retromanufacturing.com or call 702.483.2222

(See "What's in the Box" on page 4 to confirm the part(s) needed).

**NOTE: If you return a radio to us for credit, any missing parts will be debited.**

## Replaceable Items

- Main Wiring Harness
- Power Wiring Harness
- Speaker Wiring Harness
- Metal Back Strap
- Metal Hardware Pack
- Plastic Washer Kit
- InfiniMount Shaft
- InfiniMount Brackets (pair)
- Bezel / Faceplate
- Knobs

## Purchase Notes

Record the place and date of purchase for future reference.

Model No. ....

Serial No. ....

Purchase Date .....

Purchased From .....

Keep this information and your sales receipt in a safe place.





*Retro*<sup>®</sup>  
**MANUFACTURING**

MODERN SOUND FOR YOUR CLASSIC