

### PARTS LIST

**IMPORTANT:** The parts shown below may vary depending on the specific fitment purchased. The assembly procedure is the same for all fitments.

THIS GUIDE IS INTENDED FOR PART NUMBERS:  
MC-9598-FBS, MC-9598-FBR, MC-8895-FBS, AND MC-8895-FBR

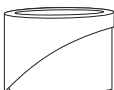
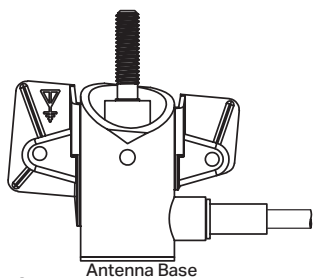

Harness  
Mounting Clip



### Step #1

Open the hood and find the antenna access cover in the inner fender.

Remove the cover to access the antenna base.

ACCESS COVER



### Step #2

Remove the antenna mast and the top nut on the antenna along with the bezel.

Remove the two screws and pull the base out.

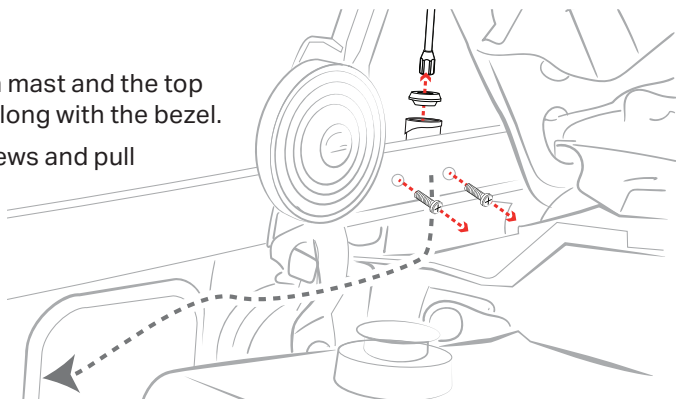

### Step #3

Mount the new antenna base and route the cable to the inner fender connector.

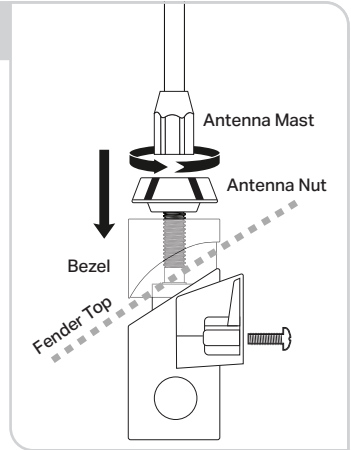
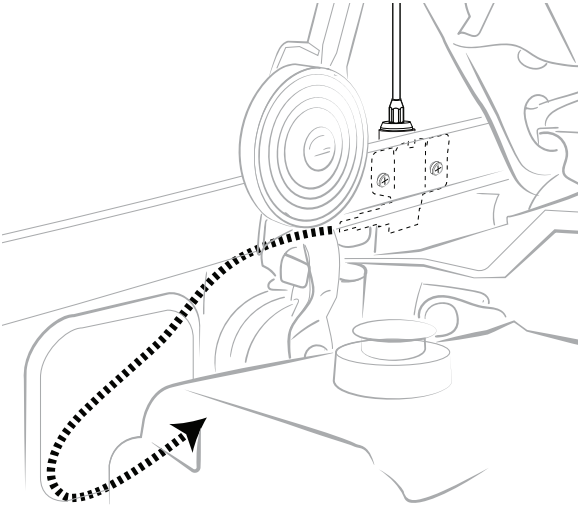

First add bezel and nut to base, then secure the antenna mast.

Secure the new base assembly to the fender with the 2 screws removed from the old base assembly.

Once the antenna assembly is fully installed and connected, replace the inner fender access cover.

For models that require the use of the extension cable. You will be replacing the entire original antenna harness.

Note the locations where the harness is routed and connected, including through the vehicles firewall. When installing the new harness the cable will need to be re-routed in the same manner and location as the original.



7470 Commercial Way,  
Henderson, NV 89011

[www.retromanufacturing.com](http://www.retromanufacturing.com)